



**ENVIRONMENTAL STANDARDS
AND
REQUIREMENTS FOR ARCHITECTURAL REVIEW**

**Lake of the Pines Association (LOPA)
11665 Lakeshore North
Auburn, CA 95602**

Revised: June 14, 2023

**WELCOME TO LAKE OF THE PINES
A CONTROLLED ENVIRONMENT COMMUNITY**

Before any changes or improvements are made to your property or the exterior of your home, you must first receive approval from the Environmental Control Committee. All requests for ECC approval must be submitted by the LOT Owner or have a signed authorization from the owner attached to the request.

MAJOR AREAS OF CONCERN ARE:

LANDSCAPING

Tree Removal and the planting of new trees and other vegetation
Excavation, drainage, and soil erosion
Fencing (safety, garden, privacy, dog, electric and decorative)
Walkways, retaining walls, patios, and driveways.
Decorative ponds, fountains and other lawn and yard ornaments
Exterior lighting – View restrictions

STRUCTURES

Room additions that change the footprint or roofline of your house
Outbuildings, pergolas, garages, sheds, gazebos, etc.
Exterior colors, roofing materials, view restrictions
Pools, hot tubs, shade screens, decks, docks, boat lifts, etc.
Placement, color and screening of LPG tanks, heating, and air conditioning units

LAKESHORES

Walls, riprap, beaches, erosion, etc.

PROPERTY LINES

Setbacks and Easements

PARKING AND STORAGE

Personal vehicles, RV's, boats, trailers, etc.
Wood, trash cans, yard tools, play equipment, etc.
Tarps and covers

All the above and many other items require Environmental Control (EC) or Environmental Control Committee (ECC) approval prior to the start of your project.

Failure to receive proper approval may result in financial penalty, requirement to remove the project and/or stopped work orders. If you have any questions regarding your project and the approval process, please contact the Environmental Control (EC) office for assistance 530-268-1141.

TABLE OF CONTENTS

1.00 INTRODUCTION

- 1.01 GENERAL INFORMATION
- 1.02 WHO WE ARE, WHAT WE DO
- 1.03 ENVIRONMENTAL STANDARDS
- 1.04 BASIC APPROVAL PROCESS
- 1.05 TIME TO COMPLETE APPROVED PROJECTS
- 1.06 TIME REQUIRED FOR ECC APPROVAL
- 1.07 ECC APPROVAL / DENIAL PROCESS
- 1.08 APPEALS
- 1.09 ENFORCEMENT OF ENVIRONMENTAL COMPLIANCE MATTERS
 - 1.09.1 INVESTIGATION OF APPARENT VIOLATIONS
 - 1.09.2 STOP WORK ORDERS
- 1.10 RESPONSIBILITY: OWNERS, TENANTS, & CONTRACTORS
 - 1.10.1 OWNERS
 - 1.10.2 TENANTS
 - 1.10.3 CONTRACTORS
- 1.11 GRANDFATHERING
 - 1.11.1 OVERVIEW
 - 1.11.2 TIME TO CORRECT
 - 1.11.3 GRANDFATHERING OF NON-APPROVED, NON-CONFORMING USE
- 1.12 VARIANCES
- 1.13 LIMITATION ON LIABILITY

2.00 PLAN SUBMITTAL REQUIREMENTS AND FEES

- 2.01 OVERVIEW
- 2.02 NEW CONSTRUCTION
- 2.03 LIVING AREA AND GARAGE ADDITIONS
- 2.04 DECKS, PATIOS, PATIO COVERS, POOLS, PERGOLAS, GAZEBOS, BOAT DOCKS, BOAT LIFTS,
- 2.05 LANDSCAPE PLANS (INCLUDING PATIOS, WALKWAYS, RETAINING WALLS, SCREENING, FENCES, DOG RUNS, DECORATIVE PONDS, ETC.
- 2.06 PROPERTY LINES
- 2.07 PLOT PLANS
- 2.08 COUNTY APPROVALS
- 2.09 FEES AND DEPOSITS
- 2.10 MODIFICATIONS TO APPROVED PLANS

3.00 BUILDINGS AND OTHER STRUCTURAL PROJECTS (HOUSE, GARAGE, SHEDS, ADU, JADU, ETC). * For ADU information please see ADU/JADU RULES (located under Document Library/ Governing Documents).

- 3.01 GENERAL REQUIREMENTS
- 3.02 DESIGN RESTRICTIONS
- 3.03 DRAINAGE
- 3.04 SETBACKS AND DRIP LINES – Residences and Garages
- 3.05 EASEMENTS
- 3.06 ENCROACHMENTS
- 3.07 EXCAVATION
- 3.08 ROOF PITCH, MATERIALS, EAVES, OVERHANGS, GUTTERS, CHIMNEY & VENT PIPES.
- 3.09 STORAGE SHEDS
- 3.10 COLORS AND EXTERIOR FINISHES
- 3.11 SEWER HOOK-UP
- 3.12 UNDERPINNINGS
- 3.13 UTILITY LINES
- 3.14 ON-SITE INSPECTION PRIOR TO PLAN APPROVAL
- 3.15 CONSTRUCTION INSPECTIONS
 - 3.15.1 FOUNDATION INSPECTION, FORMED BUT NOT POURED
 - 3.15.2 DRIVEWAY INSPECTION
 - 3.15.3 FINAL INSPECTION OF NEW HOMES
- 3.16 COMPLIANCE CERTIFICATE

TABLE OF CONTENTS

4.00 LAKEFRONT IMPROVEMENTS

- 4.01 BOAT LIFTS AND COVERS
- 4.02 CABANAS, LAKESIDE SHELTERS, GAZEBOS, PERGOLAS
- 4.03 DOCKS
 - 4.03.1 DESIGN AND PLACEMENT
 - 4.03.2 SIZE RESTRICTIONS
- 4.04 DOCKING AND STORAGE OF BOATS AND OTHER LAKE EQUIPMENT
- 4.05 HUCK FINN POND
- 4.06 HAZEL LAKE
- 4.07 BEACHES, SHORELINE PREPARATION AND LAKE ACCESS
- 4.08 EARTHEN SHORELINES
- 4.09 LAKE ACCESS
- 4.10 RECLAMATION OF ERODED PROPERTY
- 4.11 SEAWALLS AND RETAINING WALLS
- 4.12 EASEMENT RESTRICTIONS

5.00 NON-STRUCTURAL PROJECTS

- 5.01 ANTENNAS: CABLE TV AND SATELLITE DISHES
- 5.02 CULVERTS AND DRAINAGE
- 5.03 DRIVEWAYS
- 5.04 EXTERIOR LIGHTING
- 5.05 FENCING: DECORATIVE, INVISIBLE/PET, ELECTRICAL
 - 5.05.1 SAFETY FENCING
 - 5.05.2 PRIVACY FENCING
 - 5.05.3 SCREENING
 - 5.05.4 STORAGE OF RV's, CAMPER SHELLS, BOATS, TRAILERS, ETC.
- 5.06 FUEL TANKS
- 5.07 HEATING AND AIR CONDITIONING EQUIPMENT
- 5.08 LANDSCAPING
 - 5.08.1 NEW OR CHANGED LANDSCAPING
 - 5.08.2 TREE REMOVAL
 - 5.08.3 LAWN & YARD ORNAMENTS
- 5.09 MAILBOXES
- 5.10 NEWSPAPER RECEPTACLES
- 5.11 PATIOS, WALKWAYS, GOLF CART PATHS
- 5.12 SOLAR PANELS
- 5.13 SWIMMING POOLS
- 5.14 YARD AND PLAY EQUIPMENT
 - 5.14.1 TEMPORARY USE YARD AND PLAY EQUIPMENT
 - 5.14.2 SEASONAL AND PERMANENT USE YARD AND PLAY EQUIPMENT

6.00 PROPERTY MAINTENANCE

- 6.01 BUILDINGS AND STRUCTURES
- 6.02 STORAGE OF PERSONAL PROPERTY
 - 6.02.1 STORAGE OF FIREWOOD
- 6.03 DRAINAGE STRUCTURES, DITCHES, SWALES
- 6.04 FIREWISE
 - 6.04.1 ROADSIDE FIRE SAFETY

TABLE OF CONTENTS

7.00 MISCELLANEOUS ITEMS

- 7.01 BURNING
 - 7.01.1 FIRE PITS
- 7.02 DISPOSAL OF REFUGE
- 7.03 HOME BUSINESS & COMMERCIAL ACTIVITIES
 - 7.03.1 GENERAL STATEMENT
 - 7.03.2 DEFINITION
 - 7.03.3 PERMIT APPLICATION & FEES
 - 7.03.4 RESTRICTIONS
 - 7.03.5 ENFORCEMENT
- 7.04 HOUSEHOLD PETS
- 7.05 NUISANCE OR HAZARDS
- 7.06 PARKING
- 7.08 SALE OF RESIDENTIAL PROPERTY
- 7.09 SIGNS
 - 7.09.1 HOUSE AND LOT NUMBER SIGNS
 - 7.09.2 COMMERCIAL SIGNS
 - 7.09.3 REAL ESTATE SIGNS
 - 7.09.4 NON-COMMERCIAL SIGNS
- 7.10 VIEW OBSTRUCTIONS (P&P – VIEWS AND SOLOAR ACCESS)

8.00 COMMUNITY INSPECTIONS FOR NON-CONFORMING USE & COMPLIANCE VIOLATIONS

- 8.01 LOCATION OF INSPECTIONS
- 8.02 VIOLATION PROCEDURES
 - 8.02.1 FIRST VIOLATIONS
 - 8.02.2 CONTINUING VIOLATIONS
 - 8.02.3 REPEATED VIOLATIONS
 - 8.02.4 APPEAL PROCESS

9.00 ECC REVIEW OF ASSOCIATION PROPERTY

10.00 REVISIONS

11.00 DEFINITIONS OF TERMS WITHIN THIS DOCUMENT

1.00 INTRODUCTION

1.01 GENERAL INFORMATION

Lake of the Pines Association (LOPA) strongly believes that the protection and continued growth of property values through the building of an attractive community can only be assured if the Architectural Review function and Environmental Standards are rigidly and consistently administered. Experience in successful community development clearly points to the beneficial results of compatible site planning and coordinated design which also creates maximum potential for increased property values, member satisfaction and enjoyment.

With its natural Sierra Foothills environment, LOPA offers a unique living experience and should not be patterned after an urban or suburban residential subdivision. With this belief, these "Environmental Standards" have been formulated by the Environmental Control Committee (ECC) as a supplement to the Restated Covenants, Conditions and Restrictions (CC&R's). It is the purpose of this document to simplify and provide a ready reference to these rules and policies. However, it is not the function of the ECC to arbitrate disputes between owners, designers, contractors, or neighbors.

Before any changes or improvements are made to your property or the exterior of your home, you must first receive approval from the Environmental Control Committee. All requests for ECC approval must be submitted by the lot owner or have a signed authorization from the owner attached to the request.

ECC approval is required for, but not limited to:

- New home construction or any change to the footprint or roofline of your house.
- Outbuildings such as garages, sheds, gazebos, pergolas, etc.
- Roofing materials and colors, exterior colors, view restrictions.
- Placement, color and screening of LPG tanks, heating, and air conditioning units.
- Decks, docks, pools, hot tubs, shade screens, boat lifts, etc.
- Driveways, walkways, patios, fences, retaining walls, etc.
- Decorative ponds, fountains, exterior lighting and other lawn and yard ornaments.
- Tree removal and the planting of new trees and other vegetation that is or will be over three (3) feet in height at maturity.
- Seawalls, riprap, beaches, lake access, etc.
- Excavation, drainage, and soil erosion.
- Parking, storage and screening of personal vehicles, RV's, boats, trailers, etc.
- Wood stacks, trash can storage, play equipment, tarps, and covers.
- Home Business Permits.
- Solar Panels and Generators

All the above, and many other items, require ECC approval prior to the start of your project, otherwise, possible financial penalties, tear out and/or stop work orders may be issued. If you have any doubt about whether you need ECC approval for your project, or if you have any questions regarding the approval process, please call and let us help. (530-268-1141, ext. 2012).

EC department may approve, from approved color charts, colors for exterior finishes, selected roofing materials and colors, roof mounted solar panels, dead or diseased tree removal, repaving of driveways, screening of propane tanks, mailboxes, fencing, landscaping, windows, siding, and decks (like for like).

NOTE: The CC&R's article and section information noted in these standards are to assist in referencing information and are not intended to be the complete and only reference. These Environmental Standards may be a summary of, or an expansion to, other LOPA Governing Documents as authorized by Article V, Section 7 of the CC&R's.

1.02 WHO WE ARE, WHAT WE DO

(ARTICLE I – SECTION 13) (ARTICLE III – SECTION 4a) (ARTICLE V – SECTION 1, 3, 4, & 7)

The Environmental Control Committee will hereinafter be referred to as the ECC. The Environmental Control Department will hereinafter be referred to as EC.

The ECC is appointed by the Board of Directors and is responsible to the Board for monitoring environmental conditions within the boundaries of LOPA, including development and maintenance of architectural standards. The ECC is charged with the responsibility for orderly development of the community, protection of property values and the rights of all Lot owners.

The ECC is appointed, structured, and operated pursuant to the Restated Bylaws, Article IX, Section 1 and the CC&R's Article V.

EC is the Association's administrative and enforcement arm for property improvement and maintenance. The EC office is located at 11665 Lakeshore North and is normally open between 9:00 AM and 4:30 PM, Monday through Friday. The mailing address is: Environmental Control, Lake of the Pines Association, 11665 Lakeshore North, Auburn, CA 95602.

1.03 ENVIRONMENTAL STANDARDS (ARTICLE V – SECTIONS 3 & 7)

The ECC may, from time to time and with the approval of the Board of Directors, adopt, amend, or repeal rules and regulations to be known as "Environmental Standards". When adopted, the "Environmental Standards" constitutes a portion of the Association's Governing Documents and are set forth in this booklet entitled "Environmental Standards and Requirements for Architectural Review" (Standards).

1.04 BASIC APPROVAL PROCESS (ARTICLE V – SECTION 1a)

Before considering a project, members should obtain and carefully read a copy of the CC&R's and the Standards. In addition, they should obtain a checklist for submitting plans and discuss the proposed project with EC staff for additional instructions. For large-scale building plans the information needed is greater and may need to be professionally prepared. Plans must be received at the EC office no later than 5:00 pm the Thursday before the meeting at which they are to be reviewed by the ECC. Refer to Standard 2.00 for more information.

1.05 TIME TO COMPLETE APPROVED PROJECTS

Unless otherwise stated, all projects must be completed within one (1) year from the date of approval. The EC office is to be notified upon completion. Extensions may be granted on a case-by-case basis.

1.06 TIME REQUIRED FOR ECC APPROVAL (ARTICLE V – SECTION 6)

The ECC will not commence review of plans until all requirements as set forth herein are met. Plans should include the following: plot map, scope or work letter and required fees. Plans are normally reviewed and approved or denied within twenty-one (21) days of submittal, but the ECC has up to sixty (60) days to complete the initial review process. Resubmissions of changed plans will be approved or disapproved within thirty (30) days.

1.07 ECC APPROVAL / DENIAL PROCESS (ARTICLE V – SECTIONS 5, 11a)

The ECC may approve or deny plans, specifications, and details. After review by the ECC, the Member will receive back one copy of the plans and a letter advising them of the ECC's decision. The second copy of the plans will be filed in the EC office as a permanent record. Any changes in the original submission require a re-submission detailing the changes for ECC approval. No project that requires prior ECC approval shall be deemed to be approved simply because the owner completes the project without a complaint, notice of violation, or commencement of a lawsuit to enjoin such work.

1.08 APPEALS (ARTICLE V – SECTIONS 11a, 17)

Decisions of the ECC may be appealed (in writing) to the Board of Directors and submitted to the following address: Administrative Manager, Lake of the Pines Association, 11665 Lakeshore North, Auburn, CA 95602, Phone: (530-268-1141, ext. 2002).

Owners have 30 days from the approval or denial to notify the EC department if an appeal is requested. All paperwork for the appeal is due within 30 days of the notification. Fines will be generated 60 days after denial of project and any items that may need to be removed or deconstructed.

1.09 ENFORCEMENT OF ENVIRONMENTAL COMPLIANCE MATTERS

1.09.1 INVESTIGATION OF APPARENT VIOLATIONS (ARTICLE V – SECTIONS 8d, 11b)

If EC is notified or discovers a project that appears to be proceeding in violation of these Standards, the matter will be investigated, and a preliminary determination shall be made regarding the presence of a violation.

If a determination is made that the owner has failed to comply with the requirements of these Standards, the owner shall be given a written notice of non-compliance, which shall describe the nature of the alleged violation. EC may also issue the owner and/or the contractor a stop work order if an immediate abatement of work is necessary or desirable.

1.09.2 STOP WORK ORDERS (ARTICLE V – SECTION 11a, c)

EC shall have the authority to order an immediate abatement of any construction, alteration, or other matter for which ECC approval is required, and has not been approved, or if the work on the project is not proceeding in accordance with the plans and specifications submitted to and approved by the ECC.

1.10 RESPONSIBILITY: OWNERS, TENANTS, AND CONTRACTORS

(ARTICLE II – SECTIONS 2, 3, & 4) (ARTICLE IV – SECTION 4) (ARTICLE VI – SECTION 2) (ARTICLE VII – SECTION 2)

1.10.1 OWNERS (ARTICLE II – SECTIONS 2, 3 & 4)

The following is a summary of Article II of the CC&R's. Please see this Article for further explanation and details.

- (a) All owners and residents of lots within LOPA shall be subject to, and shall comply with, each provision of the LOPA Governing Documents.
- (b) Any owner may delegate his or her rights to family members, tenants, or contract purchasers who reside in the owner's residence, provided however, that any rental or lease of a residence may only be to a single family for Single Family Residential Use for a minimum thirty (30) day rental.
- (c) Owners renting or leasing their residence shall be responsible for compliance by the tenant or lessee with all the provisions of the Governing Documents during the tenant's /lessee's occupancy and use of the residence.
- (d) Owners must notify the Association of the names of any tenant or contract purchaser (including their family members) who have been given a right of occupancy.
- (e) The owner is responsible for providing any tenant or prospective purchaser with copies of all LOPA Governing Documents, which are available at the administration office.

1.10.2 TENANTS (ARTICLE II – SECTIONS 2, 3 & 4)

The following is a summary of Article II of the CC&R's. Please see this Article for further explanation and details.

- (a) The entering into a lease, or the occupancy of any lot, shall constitute the consent and agreement of the tenant or occupant to comply with all LOPA Governing Documents and Association Rules.
- (b) If any tenant or lessee fails to honor the provisions of any Governing Document or Association Rule, the Association shall be entitled to take such corrective action, as it deems necessary or appropriate under the circumstances, which may include imposition of fines and penalties against the tenant and/or Owner.

1.10.3 CONTRACTORS (ARTICLE IV – SECTION 4) (ARTICLE VI – SECTION 2) (ARTICLE VII – SECTION 2)
(R&R – “HOURS OF CONSTRUCTION” CONTRACT WORKERS)

- (a) It is the responsibility of contractors/owners to keep all mud, dirt, gravel, and debris from the streets. Driveways must be rocked immediately after they are cut. The owner will be held responsible for any damage done by utility companies. Portable toilets or sanitary facilities must be provided on the job site prior to construction. Owners, contractors, or their employees must not trespass or store materials on adjoining properties.
- (b) Entry to all job locations must be made through the LOPA authorized entry gate. No entry from Combie or Magnolia Roads or any adjoining lands will be allowed. This includes owners, contractors, sub-contractors, material carriers, employees, or anyone working on or visiting the job location.
- (c) Contractors and their employees must abide by all Governing Documents of LOPA when they are within the boundaries of the development. LOPA reserves the right to deny entry into the subdivision to anyone violating its rules.
- (d) Additionally, the CC&R's (Article VII, Section 2 and Article IV, Section 4) provide that the Association or its agent shall have the right to correct any unsightly condition on any LOT, should the contractor / owner fail to do so. All costs to make the necessary corrections shall be billed as a “Special Individual Assessment” to the owner and payment shall be due within thirty (30) days or as otherwise described in Article IV, Section 4 of the CC&R's.
- (e) No contractor or sub-contractor advertising signs will be permitted on any Lot within the subdivision.
- (f) No construction work or delivery of materials and equipment shall begin before 7:00 am, Monday through Saturday and will cease by 7:00 pm. No construction work or delivery of materials and equipment shall be permitted on Sundays or the following holidays: (New Year's Day, Memorial Day, Independence Day, Labor Day, Thanksgiving, Christmas). Exceptions to this policy must receive prior written approval from the Association Management.

1.11 GRANDFATHERING (ARTICLE V – SECTION 13)

1.11.1 OVERVIEW

Over time, the governing documents of LOPA have been changed, expanded, or new restrictions applied to some activities or structures. Many of these changes have been made to comply with changing laws, while others have been made to meet the developing needs and interests of the community.

When the requirements for a condition or use of a property that was previously approved are changed, that previously approved use may be considered “grandfathered”. This means that even though once approved, the use of the property no longer meets the community “standards”. However, under special circumstances, the “nonconforming use” of the property is conditionally allowed to continue since it is “grandfathered”.

A “nonconforming use” may consist of a previously approved structure that is no longer allowed or may consist of a missing structure that was not previously required but is now considered necessary. Additionally, an approved use becomes a nonconforming use once the conditions of the original approval are changed.

Examples of nonconforming use include types of construction that are no longer allowed such as modular homes; a house that was originally approved to be built without a garage even though garages are now required; the requirement that all driveways must now be paved; the installation of overhead power lines which are no longer approved; the type of approved screening around propane tanks etc. and many other situations.

1.11.2 TIME TO CORRECT (ARTICLE V – SECTION 13d, e)

The following is only intended to be a summary of the CC&R's Section 13 (d) and 13 (e). Please refer to these sections for further explanation.

- (a) Nonconforming Uses on Vacant lots and Nonconforming Uses involving Buildings or Structural Improvements with a replacement value of three thousand dollars (\$3,000) or less, may be continued to be maintained without being brought into compliance for a period not to exceed the lesser of five (5) years or the sale of subject property, under the following limitations:
 - (1) the use shall not be expanded or extended in any way either on the same or any adjoining lot.
 - (2) the nonconforming use shall not be changed, except to a use which conforms to the current

Governing Documents and the Environmental Standards.

- (3) the use is not discontinued for a period of twelve (12) months or more.
- (b) Any nonconforming use involving a Residence or other building improvements that have a replacement value more than three thousand dollars (\$3,000.00) shall be subject to the following:
- (1) repair and maintenance are allowed so long as during any twelve (12) consecutive months the expenditure for such repair and maintenance does not exceed twenty-five (25%) percent of the current replacement value.
 - (2) the nonconforming improvement may not be added to or enlarged without being brought into compliance with the current Governing Documents.
 - (3) a nonconforming improvement which is damaged or partially destroyed may be restored provided the total cost of repairing or restoring the structure does not exceed fifty (50) percent of the value of the Improvement. If the Nonconforming Improvement is damaged more than fifty (50) percent of its value, no repair or reconstruction shall be made unless every portion is made to conform to the current Governing Documents.
- (c) County building codes also determine the length of time that some nonconforming uses may be allowed to continue. In all cases, stricter County requirements will supersede these Standards.

1.11.3 GRANDFATHERING OF A NON-APPROVED, NONCONFORMING USE

Any use of a property, whether conforming or nonconforming, that currently exists but was not formally approved in writing by an authorized individual or committee of the Association, cannot now or in the future be considered “grandfathered”. Failure of the Association or its representative(s) to identify and/or require compliance of a nonconforming use does not qualify that nonconforming use to be “grandfathered”.

1.12 VARIANCES (ARTICLE V – SECTION 12) (ARTICLE VIII – SECTION 19)

The ECC shall be entitled to approve reasonable variances in any procedures specified in this document or Article V and Article VI of the CC&R’s, if the variance is needed to overcome practical difficulties or prevent unnecessary hardship, provided certain conditions are met. If the requested variance necessitates deviation from, or modification to, a property use restriction that would otherwise be applicable under the CC&R’s, the ECC will give a written notice to the owner requesting the variance, all owners of lots within three hundred (300) feet of the subject lot and to any other owners whom the committee considers to be affected or impacted. The notice shall also be posted in the Association’s principal office. No decision shall be made with respect to the proposed variance until the fifteen (15) day comment period has elapsed. The final decision to grant or not grant a variance will be at the sole discretion of the ECC.

1.13 LIMITATION ON LIABILITY (ARTICLE V – SECTION 15)

Neither the Association, the Board of Directors, the Environmental Control Committee, or any member thereof, shall be liable to any owner for any damage, loss or prejudice suffered or claimed on account of any mistakes in judgment, negligence or nonfeasance arising out of: (a) the approval or disapproval of any plans, drawings and specifications, whether or not defective: (b) the construction or performance of work, whether or not pursuant to approved plans, drawings or specifications: (c) the development of any lot within LOPA; or (d) the execution and filing of a Notice of Noncompliance pursuant to Article V, Section 12 of the CC&R’s, or a Compliance Certificate pursuant to Article V, Section 14 of the CC&R’s, whether or not the facts therein are correct; provided however, that such member has acted in good faith on the basis of such information as he or she possessed.

2.00 PLAN SUBMITTAL REQUIREMENTS AND FEES (ARTICLE V – SECTION 1b)

2.01 OVERVIEW

The following is an overview of the items listed (2.02 - 2.10) generally required when you submit plans to the ECC for approval. Other information may be needed depending on your project including but not limited to a Lot survey. Please refer to the sections of this document for requirements that may pertain to your project and/or visit the EC office for more information. ECC project approval should be received prior to going to the Nevada County Building Department for permits. All requests for ECC approval must be submitted by the Lot owner or have a signed authorization from the owner attached to the request. Note:

Replacement or repair of less than twenty five percent (25%) of an existing structure that does not change the original "footprint", height, design, or colors, typically does not require ECC approval. However, it is always wise to at least notify EC before starting construction. This will avoid any confusion, unnecessary inspections, and possible complaints from neighbors, etc.

2.02 NEW CONSTRUCTION

A sanitary toilet must be placed on the construction site prior to any construction activity. This facility must be placed inside the property lines.

- (a) A letter stating the basic details of your overall project (scope of work), including purpose, size, location, materials, and colors.
- (b) Plans to be submitted in electronic PDF file and one (1) set of rolled plans.
- (c) Architectural plans that include topography map, profile sketch, four fully dimensioned elevations (views), floor plans and driveway details.
- (d) Exterior paint color descriptions and color chip samples.
- (e) Signed Construction Performance Agreement (available at the EC office).
- (f) Erosion control details.
- (g) Copies of all applicable County Permits must be available before work starts.
- (h) Payment of required fees.
- (i) All Lot "new construction submittals" require topographical maps prepared by a registered Civil Engineer or licensed Land Surveyor. First floor elevation must not be less than 4.5 feet over Lake Spillway Elevation (LSE), the minimum floor elevation is 1511.5 feet.
- (j) All property lines and building perimeter shall be marked with paint, chalk, or string prior to submittal to EC and to start of construction.
- (k) Solar Panels should be installed to comply with State and County Standards

2.03 LIVING AREA AND GARAGE ADDITIONS

- (a) A letter stating the basic details of your overall project (scope of work), including purpose, size, location, materials, and colors.
- (b) Plans to be submitted in electronic PDF file and one (1) set of rolled plans.
- (c) Complete electronic pdf file of plans and one large set of roll plans as required in Standard 2.07 below.
- (d) Architectural plans that include topography map, profile sketch, four fully dimensioned elevations (views), floor plans and driveway details.
- (e) Exterior paint color descriptions and color chip samples.
- (f) Copies of all applicable County Permits must be available before work starts.
- (g) Payment of required fees.

2.04 DECKS, PATIOS, PATIO COVERS, POOLS, PERGOLAS, GAZEBOS, BOAT DOCKS, BOAT LIFTS,

- (a) A letter stating the basic details of your overall project (scope of work), including purpose, size, location, materials, and colors.
- (b) Plans to be submitted in electronic PDF file and one (1) set of rolled plans.
- (c) Dock plans must also show extended property lines and setbacks into the lake, distances from shoreline and setbacks, size of dock and materials used. See Section 4.03 of this document for further dock requirements.
- (d) Copies of all applicable County Permits.
- (e) Payment of required fees.
- (f) All patio/deck covers that appear from the plan view, visually appear to be attached, shall be part of the house/structure and must conform to all setback requirements as defined in Environmental Standards Section 3.04.

2.05 LANDSCAPE PLANS (Including patios, walkways, retaining walls, screening, fences, dog runs, decorative ponds, etc.)

All owner modifications or improvements beyond the front property line and onto Association property require prior ECC approval as per Article VII, Section 1(b) of the LOPA CC&Rs. Improvements of any sort cannot encroach into the FUEL MODIFICATION AREA, a 10-foot strip of land abutting the roadway. (See EC standard 6.04.1 for details). Any such modifications or improvements are the lot owners' responsibility to maintain it in a neat and orderly fashion. NO excavation is allowed without prior ECC approval.

EXCEPTION TO THE ABOVE RULE: If a Lot owner wishes to landscape into the FUEL MODIFICATION AREA further steps need to be taken. An application to the Environmental Control Committee is required. Proposed landscaping must conform to the strict provisions of Nevada County Ordinance. Said ordinance limits the type and size of allowable plants, the pattern of planting and requires ongoing maintenance plus irrigation. A review of EC Standards section 3.06 is therefore relevant. The Association will require the execution of a basic MEMORANDUM OF UNDERSTANDING AND MAINTENANCE AGREEMENT.

- (a) A letter stating the basic details of your overall project (scope of work), including purpose, size, location, materials, and colors.
- (b) Plans to be submitted in electronic PDF file and one (1) set of rolled plans.
- (c) Dimensions of all planting areas.
- (d) A list of proposed plants, their sizes at mature growth, keyed to their location on the plot plan.
- (e) Details of any proposed features such as ponds, fences, imported rocks, etc.
- (f) Comply with Firewise approved plantings and Fuel Modification Area requirements in section 6.04.1

2.06 PROPERTY LINES

It is the owner's responsibility to establish Lot boundaries (property lines) by locating property corner stakes. If they cannot be found, a survey must be conducted to establish the boundaries. It shall be the responsibility of the owner and builder to then stay within setback lines. LOPA and EC will not be responsible for errors in Lot boundaries or setbacks. Inspections made by EC are for approval of plans and layouts and do not constitute confirmation of property boundaries. Property lines are the sole responsibility of the owner, and it is the responsibility of the owner(s) to resolve any property line disputes. Should any questions exist regarding property lines, they must be verified by a registered Civil Engineer or licensed Land Surveyor.

2.07 PLOT PLANS

A plot plan is a scale drawing with the scale called out at no smaller than one (1) inch equals twenty (20) feet, showing **IN BOLD** all property lines, setbacks, easements, abutting street names and adjoining lot numbers. Plot plans shall include a "North" orientation; existing and proposed grade contour lines on two (2) foot increments; finished floor elevations; dimensioned location of all retaining walls including top and bottom of wall elevations; and dimensioned hardscape plans including spot elevations of all hardscape surfaces. It shall also show existing and proposed drainage, all Cut and Fill with quantities, all trees over three (3) inches in diameter (as measured four (4) feet above the ground) and other lot features. The plans must show all buildings, driveways, parking areas, decks, patios, external fuel tanks, trash container enclosure, and any projects proposed to be constructed or altered, and their dimensions and relationship to the property lines.

2.08 COUNTY APPROVALS

When appropriate, plans must be submitted to the Nevada County Building Department and the owner is responsible for payment of all required county permit fees. Approval of any project by the ECC does not waive the necessity of obtaining the required County Permits, nor does obtaining a County Permit waive the need for ECC approval. The ECC will not knowingly approve a project which is in violation of the County Building or Zoning Codes.

2.09 FEES AND DEPOSITS (ARTICLE V – SECTION 8)

Plan submittals must be accompanied by the applicable fees and deposits.

All fees and deposits will be paid by the owner, or in the owner's name. Fees are normally non-refundable. However, if construction is cancelled within one (1) year, all but the actual costs incurred by the Association will be refunded. Deposits may be refunded in whole or in part, depending on compliance with the Environmental Standards and satisfactory sign-off of EC final inspection. Deposits not claimed shall be processed in accordance with the Association Accounting Procedures.

2.10 MODIFICATION TO APPROVED PLANS (ARTICLE V – SECTION 1d)

Any request for modifications or changes to previously approved plans must be submitted to the ECC and receive approval prior to the start of work.

3.00 BUILDINGS AND OTHER STRUCTURAL PROJECTS (HOUSE, GARAGE, SHEDS, ADU, JADU, ETC).

(ARTICLE VI – SECTION 2, ARTICLE VIII – SECTION 4)

*** For ADU information please see ADU/JADU RULES (located under Document Library/ Governing Documents).**

3.01 GENERAL REQUIREMENTS (ARTICLE VI – SECTION 3, 6, & 9) (ARTICLE VIII – SECTION 4)

Besides the information listed in this section, be sure to check Section 4.00 "Lake Front Improvements" and Section 5.00 "Non-Structural Projects" for any subjects that may be pertinent to your project.

- (a) No residence, garage, building, fence, wall, or other structure or improvement shall be erected, altered, or placed on any Lot until the project has received ECC approval.
- (b) All residences shall be constructed by a State of California licensed contractor, although an owner shall not be precluded from acting as his or her owner/builder as permitted by law. No LOT shall be used for any purpose other than single-family residential use except that ADU's and JADU's may be built if they comply with all State, County and LOPA regulations, laws, and policies, and obtain all approvals and the payment of all associated permits and fees.
- (c) No structures shall be erected, placed, or permitted to remain on any LOT other than one (1) detached, single-family residence and such outbuildings as are appropriate to a single-family residence.
- (d) In no event shall more individuals than permitted by local law or governmental regulations occupy a residence. To further the intent of this section, no more than one (1) kitchen facility shall be installed or maintained in any residence, except as allowed by a County Special Use Permit for senior citizen or disabled family members and such facilities must receive ECC approval and be removed immediately upon a change of intended use or the sale of property except as provided in the CC&R's Article VI.
- (e) Section 6 and Article VIII Section 17d, no RV, trailer, mobile home, camper, tent, shack, or other structures of a temporary character shall be placed on any LOT and in no instance may they be used as living quarters.
- (f) No used building or structure that is intended for residential use shall be placed on any LOT. All new construction must consist of a substantial amount of new material.
- (g) All Patio/Deck covers that appear from the plan view, visually appear to be attached, shall be part of the house/structure and must conform to all setback requirements as defined in Environmental Standards Section 3.04.

3.02 DESIGN RESTRICTIONS (ARTICLE VI – SECTIONS 1, 4, 7, & 19)

- (a) Residential dwellings shall contain a minimum of twelve hundred (1,200) square feet of fully enclosed floor area, devoted to living purposes exclusive of porches, terraces, garages, or outbuildings.
- (b) Mobile homes are not permitted on any lot within the subdivision boundaries.
- (c) An enclosed garage containing a minimum of four hundred (400) square feet of parking space is required.
- (d) Except as provided in the CC&R's Article VI, Section 1, no residence, or accessory building shall have more than one story. With the prior approval of the ECC in accordance with the CC&R's Article V, this single-story height restriction may be modified to permit construction of a split level or two-story residence where, in the opinion of the ECC, the terrain of the Lot lends itself to such construction without harming the view from, or solar access to existing or potential neighbors or

common areas.

- (e) The height of primary residential buildings and any NEW CONSTRUCTION on any residential Lot shall be restricted to a maximum twenty-nine (29) feet, measured by the vertical distance from the highest point of the structure to the average of the highest and lowest points where the exterior walls touch the natural grade as shown in the below illustration, or split-level or two-story residences only. For single story residences, a maximum height is twenty-four (24) feet. Secondary, stand-alone structures such as separate garages and car ports shall be restricted to a maximum height of nineteen (19) feet measured in the same manner as main residential buildings.
- (f) A variance may be requested on lots with an average natural slope greater than fifteen (15) percent and the conditions of Section 1.12 of these standards are met. Under no circumstances will a structure on any residential lot be allowed to exceed thirty-five (35) feet in height.
- (g) Architectural plan submissions requesting a height restriction variance must contain height and width dimensions on all four elevations (view) plans. The ECC will take into consideration, but are not limited to, the following items:
 - (1) The size of the lot, the structures placement on the lot and the setbacks to the property lines.
 - (2) How the proposed structure fits in with the neighboring structures.
 - (3) Whether the mass of any side view will be considered objectionable to neighboring views.
 - (4) Any landscaping aspects (plans) that may help reduce the impact on the mass of any side view.
- (h) Side setbacks are tied to the height of the structure. See Section 3.04 for setback requirements.

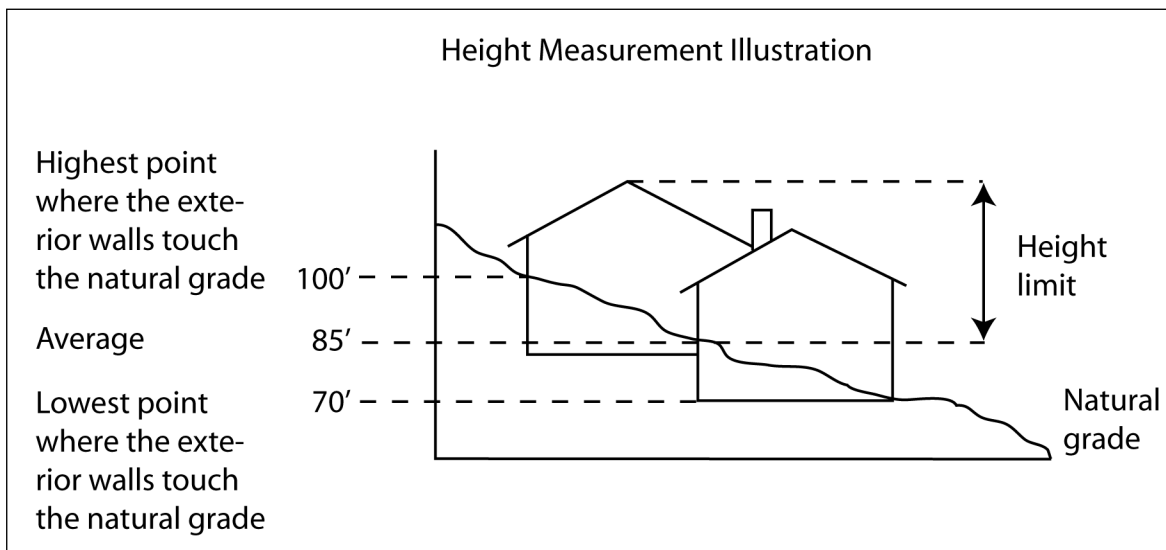

3.03 DRAINAGE (ARTICLE VI – SECTION 14)

No owner shall do any work, construct any improvement, place any landscaping, or suffer the existence of any condition whatsoever that shall alter or interfere with the drainage pattern established in connection with the approval of the final subdivision and parcel maps applicable to LOPA by Nevada County except to the extent that such alteration in drainage pattern is approved in writing by the ECC and County.

3.04 SETBACKS AND DRIP LINES – Residences and Garages (ARTICLE VI – SECTION 5)

Placement of proposed structures should be compatible with neighboring structures and have minimal impact on neighboring views.

- (a) DRIP-LINES are defined as the outer extremities of roofs, eaves, decks, steps, enclosed patios, and garages, and are used in determining setbacks.
- (b) FRONT SETBACK is a minimum of thirty (30) feet from the front property line of each lot abutting a street right-of-way to the front drip line of the structure. For most homes, the front property line is approximately thirty (30) feet from the street center line. For the purpose of these Standards, the "front" of a lot or residence shall be the side that faces the mailing address street. All projects require boundary line verification per Nevada County Standards. All lakefront homes are required to have the property surveyed before any additions/construction is made.

- (c) SIDE SETBACKS for one story residences and garages are a minimum of five (5) feet from the drip line to the side property line. If a variance is granted for eaves less than eighteen inches (18) as measured from finished wall, then the side setbacks must not be less than six and one-half (6.5) feet from the side property line to the structure's foundation. See "Corner lots" in item (e) below for information on corner lot setbacks. Side setbacks for ANY NEW CONSTRUCTION of Split Level and two-story structures are a minimum of seven and half feet (7½) feet from the drip line to the side property line or nine (9) feet from the structure's foundation to the side property line.
- (d) REAR SETBACK from the rear property line to the rear drip line shall be the greater of twenty (20) feet, or twenty-five percent (25%) of the depth of the lot. Exceptions to this rule are as follows:
 - (1) On properties contiguous to the golf course, the rear setback to the drip line shall be the greater of twenty-five (25) feet or twenty-five percent (25%) of the depth of the lot.
 - (2) On properties contiguous to the Main Lake, Hazel Lake, or Huck Finn Pond, the rear setback to the drip line shall be the greater of fifty (50') feet or twenty-five (25%) percent of the depth of the lot, whichever is greater. The depth of the lot and setback is measured by using the normal water level of each lake as determined by the lake spillway elevation (LSE) on LOPA main lake; the spillway on Huck Finn Pond; and the overflow pipe on Hazel Lake.
 - (3) On properties that back up to Combie Road, Magnolia Road, and Darkhorse, rear lot setbacks will be considered on a case-by-case basis and must meet County standards.
- (e) CORNER lots must maintain both the thirty (30) foot front setback and shall maintain a twenty (20) foot setback from the other street side property line. The front of the lot is the side that faces the mailing address street. Corner lots may be dealt with on a case-by-case basis.
- (f) IRREGULAR BOUNDARIES: Where lot boundaries are irregular, contact the EC office to determine the setbacks. In no case can a structure be closer than fifty (50) feet from the lakeshore line or twenty-five feet (25) from the golf course.
- (g) EASEMENTS: No structures are allowed within LOPA easements. All landscaping plans and other similar improvements must be approved by the ECC prior to starting planting, construction, or excavation.

3.05 EASEMENTS (ARTICLE IX – SECTIONS 1, 2, 3, 4, & 5)

An easement is an interest in land owned by another that entitles its holder to a specific, limited use of enjoyment. Some of these easements and/or rights-of-way are:

- (a) Ten (10) feet width along the front property line and five (5) feet width along the side and back property lines, for the purpose of public utility and television cables.
- (b) For the use and maintenance of any kind of drainage.
- (c) For maintenance and permanent stabilization control of LOPA in a slope control area.
- (d) An easement of ten (10) feet inland from the shoreline of any lake or pond is required for shoreline maintenance and control.

On each lot, the right-of-way and easement areas reserved by LOPA or dedicated to public utilities, must be maintained by the lot owner, but no structures, plantings (excluding minor landscaping), or other material shall be placed or permitted to remain upon, or other activities undertaken, which may damage or interfere with access to, or the installation and maintenance of utilities.

3.06 ENCROACHMENTS

The Association has a sixty (60) foot right-of-way for roads, approximately thirty (30) feet on either side of the road's centerline. Except for minor landscaping, only a licensed contractor is allowed to work within this easement. Licensed contractors shall provide LOPA a certificate of insurance and a bond with the current limits required. (Please check with the EC Department for current limits). EC must be notified at least three (3) calendar days prior to the start of any work.

All modifications or improvements between the roadway and the front of the lot are the lot owner's responsibility to maintain, repair and replace per Article VII, Section 1 (b) of the LOPA CC&Rs. No excavation allowed, without prior ECC approval.

Preservation of street paving and shoulders is highly important in LOPA and care must be taken to assure that no damage occurs. No cuts into or across LOPA roads are permitted. Any damage to street or shoulder paving, roadside ditches, and shoulder right-of-way, must be repaired or replaced to its original condition or better at the lot owner's expense.

3.07 EXCAVATION

Excavation should be kept to a minimum. LOPA has a very high erosion factor, and a high percentage of ground erosion finds its way into our lake. Therefore, considerable attention must be taken to prevent erosion. When making a cut for a driveway or any other excavation, the slope of the cut should be a thirty (30) degree incline or less. On cuts greater than thirty (30) degrees, slope stabilization is required and must be approved by the ECC and Nevada County. Contact EC for suggested methods of stabilization.

3.08 ROOF PITCH, MATERIALS, EAVES, OVERHANGS, GUTTERS, CHIMNEY & VENT PIPES.

(ARTICLE VI – SECTION 12 & 13)

- (a) The preferred minimum roof pitch is four (4') twelve (12').
- (b) Roofing materials must meet all County Ordinance's, consist of Class A fire retardant materials, and receive ECC approval. Colors must harmonize with the environment rather than be intrusive or command attention. A roofing sample must be included when submitting your request to the ECC.
- (c) All residential and garage structures must have eaves with an eighteen (18) inch minimum overhang, as measured from finished wall, unless otherwise approved by the ECC. If approval is granted for eaves less than eighteen (18) inches as measured from finished wall, the side setbacks must not be less than six and one-half (6.5') feet from the side property line to the structure's foundation.
- (d) The ECC may also require eaves on other structures such as outbuildings, sheds, gazebos, etc., and the minimum overhang required will be based on the size and appearance of the structure.
- (e) All residential and garage eaves must have approved gutters and downspouts and when deemed necessary, piping that carries the water toward the appropriate drainage. The ECC may also require gutters and downspouts on the above-mentioned outbuildings when deemed necessary to avoid erosion and excessive water flow to neighboring properties. All gutters and downspouts must be painted in either the trim or body color of the house.
- (f) A chase of a design and color compatible with the building must be provided for all chimney flue pipes. The chase is part of the roof structure and must comply with Nevada County requirements for passage of metal flue pipes. The chase must extend to a minimum of eight (8) inches and a maximum of twelve (12) inches from below the bottom of the flue cap.

3.09 STORAGE SHEDS (ARTICLE VI – SECTION 21) (ARTICLE VIII – SECTION 16)

For the purpose of these documents, a "Storage Shed" is defined as any outbuilding with a maximum footprint of two hundred (200) square feet and a maximum height of twelve feet (12). Any outbuilding larger than two hundred (200) square feet and a maximum height of twelve feet (12) will be treated as a permanent structure and fall under the guidelines of a garage or home addition. Storage sheds may be no closer than five feet from the side property line, ten feet from the rear property line and thirty (30) feet from the front property line. Limit of two sheds per lot.

All storage sheds, utility cabinets, boxes, or structures of any kind, whether constructed on the premises or manufactured and regardless of location, must receive ECC approval. Location, design, materials, and colors must be compatible with the design and exterior of the residence.

3.10 COLORS AND EXTERIOR FINISHES (ARTICLE VI – SECTION 11)

All exterior colors, finishes and materials (including roofing), whether for new construction or repair and maintenance of existing structures, must be approved by the ECC. A chart of approved colors is available in the EC office and all plans submitted to the ECC must adequately describe the colors and include samples or paint chips.

- (a) Colors must harmonize with the environment, rather than be intrusive or command attention.
- (b) All bright or reflective surfaces, including garage doors, must be painted with a non-reflective color. Flat or Satin finishes are recommended.
- (c) Garage doors should be painted the same color as the main body of the house when practical.
- (d) Outbuildings are to be painted the same color as the house.
- (e) Protective covers used on such items as, but not limited to, cars, boats, RV's, woodpiles, etc., must be of a design and color as permitted by the ECC.

3.11 SEWER HOOK-UP (ARTICLE VI – SECTION 18)

Per Nevada County requirements, all existing and newly constructed homes must be connected to the sewer system unless sewer mains or branch lines are not available.

Some residents with property on Wanderer Road and Wayfarer Court have special circumstances and are not part of the Sanitation District. Check with the Department of Public Works for pertinent information.

Many homes in LOPA have sewage holding tanks and pump their sewage uphill to the main sewer line. A holding tank with a minimum five hundred (500) gallon capacity is recommended unless the Nevada County Sanitation District requires a larger tank.

3.12 UNDERPINNINGS

ECC approved screening of underpinnings, foundations, bracing structures, exposed plumbing, heating/cooling units and the underside of decks may be required if deemed appropriate.

3.13 UTILITY LINES (ARTICLE VI – SECTION 8)

All utility lines running from utility poles to improvements within LOPA must be placed underground.

3.14 ON-SITE INSPECTION PRIOR TO PLAN APPROVAL

All “new home” submissions require an on-site inspection by the ECC prior to plan approval and all the criteria listed below must be met prior to that inspection. Major renovations and room additions may also require on-site inspection if deemed necessary and one or more of the criteria listed below may be required prior to that inspection.

The passing of an Inspection does not preclude the owner’s responsibility to build according to the approved plans.

- (a) A lot number sign must be in place.
- (b) Debris, brush, and tall grass must be sufficiently removed to allow access for inspection.
- (c) Property corners must be established with permanent markers and property lines strung in all areas that may have setback issues.
- (d) Foundation lines must be strung or otherwise clearly marked.
- (e) Ribbons must be placed on all trees of three (3) inches or more in diameter as measured from four (4) feet above the ground, that you are requesting approval to remove.
- (f) Any proposed changes to the Association or common drainage must be approved by the LOPA Public Works Department.
- (g) Upon request of the ECC or its inspector, a “story pole” or “ridge pole” must be erected indicating each floor level and/or the maximum height of the structure. The ECC may use this pole as a visual aid in determining whether the height of the structure meets the requirements set forth in the CC&R’s and this document. The ECC, at its discretion, may pick another more permanent point of reference to determine the maximum height of the structure. Such a determination shall be supplied in writing with the ECC approval of the structure. It shall be the owner’s responsibility to make sure that the structure does not exceed any height restrictions placed on the project.

3.15 CONSTRUCTION INSPECTIONS

A sanitary toilet must be placed on the construction site prior to any construction activity. This facility must be placed inside the property lines.

The passing of an Inspection does not preclude the owner’s responsibility to build according to the approved plans.

3.15.1 FOUNDATION INSPECTION, FORMED BUT NOT POURED:

- (a) At least one (1) board of the outer foundation forms must be in place. It is the Owner’s responsibility to ensure that the foundation is correctly located in accordance with the property line markers for their

lot and to ensure the approved setback is retained. EC must be notified at least twenty-four (24) working hours prior to the pour.

- (b) The driveway must be cut and graveled.

3.15.2 DRIVEWAY INSPECTION:

Inspection must be made to all driveways that cross Association easements, after any drainage is installed and base rock compacted, prior to paving. When culverts are installed, concrete bulkheads will be required. Contact EC for further information on street openings, street closures and compaction requirements. EC must be notified at least twenty-four (24) working hours prior to paving. Paving is to be applied in accordance with the approved plans.

3.15.3 FINAL INSPECTION OF NEW HOMES: (ARTICLE VIII – SECTION 6)

No residence may be occupied until the County Building Inspector has issued a “Notice of Occupancy” and a “Final Inspection” is performed and passed by EC. EC must be notified at least twenty-four (24) working hours prior to your request for final inspection. The final inspection may include any or all the following:

- (a) Exterior conformity of plans.
- (b) Chases for chimney flue pipes.
- (c) Painting of all exterior surfaces.
- (d) Material usage and color conformity to plans.
- (e) Location and screening of fuel tanks, heat, and cooling units, etc.
- (f) Grading and erosion control.
- (g) Removal of debris.
- (h) Roadway, roadside ditches, and shoulder encroachments.
- (i) Driveway encroachments.
- (j) Culvert and drainage control.
- (k) Eaves, gutters, and downspouts.
- (l) Setbacks.
- (m) Roof pitch.
- (n) Embankment damage.
- (o) Utility connection.
- (p) Damage to adjoining properties.
- (q) House number sign.
- (r) Solar panels.
- (s) County final inspection.

If after the inspection, EC determines that additional work is necessary to bring the property into compliance and these discrepancies are not corrected within thirty (30) days, the Association may take corrective action. The cost to make the necessary corrections will be billed to the owner and the owner is responsible for any costs that exceed the performance deposit. The Association has the right to place a lien against the owner’s property for all unpaid expenses.

3.16 COMPLIANCE CERTIFICATE (ARTICLE V – SECTION 14)

Within thirty (30) days after the owner supplies a written request to EC, and upon payment to the Association of the fee, EC shall provide the requesting owner with a Compliance Certificate, commonly referred to by law as an “estoppel certificate”, certifying that as of the date thereof, all improvements made and other work completed by the owner, comply with this Declaration. More detail is available in the CC&R’s, Article V, Section 14.

4.00 LAKEFRONT IMPROVEMENTS (ARTICLE VIII – SECTION 5)

ECC approval is required before any structure can be built, or any material deposited or placed into the lake or on the lakeshore, or in a position where it could be washed or pushed into the lake. Any proposed form of dredging, digging, or moving of sediment on the shoreline or in the lake also requires ECC approval. Owners must maintain their waterfront to prevent shoreline erosion. Besides the criteria listed in this section, all structures placed near the shoreline or on the lake will be subject to ECC review for its visual impact on

neighboring properties. All submissions to the ECC or decisions of the ECC, pursuant to Sections 4.07, 4.08, 4.09, 4.10 and 4.11, will be copied to the Chairman of the LOPA Lake Committee. When deemed appropriate, the ECC may seek the recommendations of the Lake Committee prior to rendering a decision. The minimum floor elevation for lakefront properties shall be 1,511.5 feet.

Lakefront improvements using electrical power require a County Building Permit. The Property Owner is required to maintain the electrical service in a safe and operable condition. All lakefront improvements placed on or near the Association's property remain the sole responsibility of the lot owner to maintain, repair and replace.

4.01 BOAT LIFTS AND COVERS (ARTICLE VIII – SECTION 15)

All boat lifts and covers must be approved by the ECC and are subject to removal at the owner's expense if deemed necessary and at the sole discretion of the Association.

- (a) Boat lifts shall be installed per manufacturer's specifications, a copy of which will be included with the request for approval.
- (b) Suitable surface markers indicating the existence of a submerged boat lift shall be required for safety purposes, (e.g., buoys).
- (c) Placement of boat lifts shall be adjacent to the dock and shall not extend beyond the end of the dock nor protrude within five (5) feet of the extended property line, measured from the drip line of the boat lift or canopy, when applicable. The ECC will also consider the visual impact on neighboring properties when reviewing boat lift placement. A plot map shall be submitted showing the location of the boat lift in relation to property lines extended into the lake.
- (d) Boat lift covers also need ECC approval and the cover shall not exceed eleven (11) feet in width or twenty-five (25) feet in length or hang down over two (2) feet on the sides. Boat lift covers must be gray in color and mounted according to the manufacturer's specifications unless otherwise approved by the ECC.
- (e) Only two (2) boat lifts are allowed per lot.

4.02 CABANAS, LAKESIDE SHELTERS, GAZEBOS, PERGOLAS

ECC approval must be obtained for the construction or placement of a cabana, lakeside shelter, or gazebo on any lot. The following factors shall apply and be considered by the ECC when reviewing your plans.

- (a) An open-air look that blends in with the surroundings.
- (b) The structure shall have minimum impact on neighboring views, with setbacks of five (5') feet from the side property line, ten (10) feet from the rear property line and thirty (30) feet from the front property line.
- (c) When built on the lake easement and access to the easement is required, such structure shall be removed at the owner's expense when and if deemed necessary by the Association.
- (d) The owner of a lakeshore Lot may not infringe beyond the shoreline into the lake, except for ECC approved boat docks and boat lifts.
- (e) The maximum solid roof area shall not exceed two hundred (200) square feet and neither one side is to exceed twenty (20) feet in length. Gazebos are considered a solid roof structure and shall not exceed (200) square feet. Pergolas are considered an open roof structure and shall not exceed four hundred (400) square feet.
- (f) Maximum side height from floor is eight (8) feet and maximum overall height from floor is no more than twelve (12) feet.
- (g) No overhang is to exceed two (2) feet.
- (h) The structure shall be constructed with approved materials and shall be kept as close to the ground as practical.
- (i) No permanent foundations will be allowed within lake easements.
- (j) Natural stains or neutral colors shall be used and where applicable shall blend with the main house.
- (k) No permanent screening is allowed.
- (l) One gazebo and one pergola may be approved per lot unless special consideration is needed for large parcels.
- (m) No plumbing or appliances may be installed except for a water faucet and BBQ grill.
- (n) The lighting must be well shaded and subdued.
- (o) No expansion or alteration of structure will be allowed without prior permission of the ECC.

4.03 DOCKS

Lakefront property owners must have a dock installed to moor any boats on the lake. A seawall does not qualify as a dock. Owners unable to install a dock because of building difficulties may be eligible for a variance. Design and construction of docks must be approved by the ECC, and like all other improvements, they must be maintained in a satisfactory condition. All docks are subject to removal at the owner's expense if deemed necessary and at the discretion of the Association.

4.03.1 DESIGN AND PLACEMENT

- (a) Only one dock is allowed per lot. A lot survey must accompany any request for dock amendment or construction.
- (b) Owners assume full responsibility for the design, placement, and maintenance of their dock. Some factors to be considered when designing and/or submitting plans for a dock are its location on the lake, wave action, the depth of water, underwater obstructions, obstruction of neighboring views, taking into consideration any boats, boat lifts, etc., that may be stored dockside, and converging property lines, especially within coves.
- (c) Due to the frequent wave action on our relatively small lake, docks of a fixed design are highly recommended over that of a floating design.
- (d) All docks must be installed a minimum of five (5) feet from the extended side property line. If a boat lift is to be installed, or a boat is to be moored or stored alongside the dock, then the dock must be positioned to be fifteen (15) feet from the extended side property line. Docks, boat lifts and boats may NOT extend more than thirty (30) feet from the shoreline. A plot map shall be included with all submissions to the ECC that show the location of the dock in relation to the extended property lines.
- (e) No boat may be stored, or boat lift positioned in such a way that it will extend into the water further than thirty (30) feet from the shoreline of the Main Lake as established by the LSE, or twenty (20) feet from the shoreline of Hazel Lake as defined by the spillway-height.
- (f) Entry to your dock or boat lift shall not require you to maneuver your boat over the extended property line of your neighbor.
- (g) Docks, including all attachments, walkways, boat covers, boat lifts and their covers, shall be maintained in such a manner as to prevent them from becoming structurally unsound, unsightly by reason of substandard exterior stain or painting, deterioration of carpet, bumpers, components, or any other aesthetic feature.

4.03.2 SIZE RESTRICTIONS

The construction of docks must also meet the size requirements listed below. Any portion of a "deck" which protrudes into the lake beyond the LSE is considered a "dock", must meet all "dock" requirements, and that portion protruding into the lake will be calculated as part of the maximum square footage allowed for a dock.

- (a) Maximum square footage (including gangway).
 - (1) Two hundred twenty-five (225) square feet for an "I" shaped dock.
 - (2) Two hundred fifty (250) square feet for a "T" or "L" shaped dock.
 - (3) Three hundred (300) square feet for a "U" shaped dock.
- (b) The maximum length of a dock, including gangway, shall be no more than thirty (30) feet from the shoreline as established by the LSE.
- (c) The maximum height of a dock is two (2) feet above the LSE water level.
- (d) The minimum width of any I, T, U or L shaped dock area (excluding gangways) is four and one half (4.5') feet.
- (e) There may not be any structure on the dock higher than four (4) feet above the dock's surface.
- (f) The minimum width of any gangway is four (4) feet.

4.04 DOCKING AND STORAGE OF BOATS AND OTHER LAKE EQUIPMENT

Boats and other lake equipment must be stored and secured dockside with no portion of any boat or other lake equipment extending into the lake further than thirty (30) feet from the shoreline of the main lake or twenty (20) feet from the shoreline of Hazel Lake. Any lake equipment stored on shore must be done so in such a manner that they do not create a visual nuisance.

4.05 HUCK FINN POND

Due to the size, depth and unique nature of this pond, different rules apply than those for the Main Lake or Hazel Lake.

- (a) Docks may not exceed one hundred (100) square feet in size and may not extend more than ten (10) feet from the shoreline.
- (b) No powerboats are allowed. Rowboats, pedal boats, canoes, and similar watercraft are acceptable.
- (c) Beach improvements are not allowed (e.g., sand, gravel, etc.)

4.06 HAZEL LAKE

Due to the size, depth and unique nature of this lake, different rules apply than those for the Main Lake.

- (a) Docks are allowed on Hazel Lake, but along with the requirements under Section 4.03, the following restrictions also apply.
 - (1) The maximum extension of a dock is twenty (20) feet from the shoreline as defined by the spillway height.
 - (2) The maximum square footage of the combined dock and gangway is one hundred twenty (120) square feet.
 - (3) The dock surface must not be more than two (2) feet above the surface of the water at normal spillway height.
 - (4) Lights on docks are discouraged. However, if there is a need for safety lights, they must be limited in number, be a low intensity, non-obtrusive lighting and be turned off or extinguished when not in use.
- (b) No improvements are allowed within ten (10) feet of the waterfront.
- (c) Other than existing beach improvements, which have been approved by the ECC, no further beach improvements are allowed (e.g., sand, gravel, etc.)

4.07 BEACHES, SHORELINE PREPARATION AND LAKE ACCESS

The following rules are for lakeshore residents interested in constructing beaches or pedestrian lake access between their house and the lake.

- (a) The owner of a lakeshore lot may not infringe beyond the shoreline lake spillway elevation (LSE), except for the building of boat docks or approved erosion control projects (riprap).
- (b) Written approval from the ECC is required before any material can be deposited or placed in the lake, or on the lakeshore in a position where it could be washed or pushed into the lake. This includes any form of dredging, digging, or moving of sediment on the shoreline or in the lake.
- (c) Since each property is different, methods that work well on one lot may not be effective on another. The following are some examples of beach stabilization, but all need ECC approval.
 - (1) A seawall may be built to prevent shoreline erosion and a beach may be developed between the house and the seawall. (See Section 4.11 for information pertaining to Seawalls).
 - (2) Steeply angled waterfront lots are difficult to modify into a beach because winter rains can wash sand into the lake. The beach angle must be as horizontal as possible, and it may be necessary to construct a berm or French drain around the upper side of the beach to divert storm water. If the ECC deems it necessary, they may require the lot owner to hire a licensed Civil Engineer to aid in the design of appropriate beach or lakeshore access that will still effectively prevent erosion.

4.08 EARTHEN SHORELINES

- (a) Earthen shorelines with gradual slopes may be protected by planting certain species of water tolerant plants over special netting.
- (b) Moderate slopes may need shoreline protection with the use of boulders or large rocks interspersed with smaller rocks.
- (c) Steep slopes may necessitate the need for a seawall. (See Section 4.11 for more information).

4.09 LAKE ACCESS

All homeowner access into the lake must be submitted to and approved by the ECC prior to construction. Methods of providing pedestrian access to the lake that work on one lot may not be appropriate for another. Access to the lake may include concrete steps or paths, a notched seawall, or other alternatives.

4.10 RECLAMATION OF ERODED PROPERTY

Some lakeshore properties may have had erosion, the exact extent of which may be difficult to determine. If a lakefront property owner desires to reclaim lost property due to erosion, the owner is required to demonstrate where "the original shoreline was" or "where it would be at the LSE". This may be done by various means but must meet the satisfaction of the Association. The owner may enlist the services of an approved engineering service to estimate the LSE.

4.11 SEAWALLS AND RETAINING WALLS

Plans for any seawall or retaining wall must be submitted to, and approved by the ECC, prior to the start of construction. Each property is different and may require different design considerations. Seawalls may be built of concrete, concrete blocks, bricks, slump stone, or any other suitable material. An attractive facing must be incorporated on any portion of the seawall that is visible above the LSE. The lakeside of the seawall must not protrude past the LSE.

Upon new construction or reconstruction of existing seawalls, ECC may require that the seawall be stabilized with concrete footings, boulders and rocks, or other suitable materials. The ECC may consider recommendations from the Lake Committee prior to approving any seawall or riprap plans. In any case, any material placed in the lake must first receive ECC approval. Riprap may extend into the lake the distance necessary to establish a minimum 2:1 slope. The riprap may protrude a maximum of one (1) foot above the water surface at LSE, and the material chosen must be such that it will not erode or be washed into the lake by wave action. Sand, earth, or clay may not be placed in the lake under any circumstance.

4.12 EASEMENT RESTRICTIONS

There is a Utility Maintenance Easement for lake and shoreline maintenance along the lakefront portion of each lot. This easement is ten (10) feet wide and is measured from the shoreline at LSE, regardless of property markers.

5.00 NON-STRUCTURAL PROJECTS

5.01 ANTENNAS: CABLE TV AND SATELLITE DISHES (ARTICLE VI – SECTION 15)

All new homes and homes under construction must have an underground cable connection running to the house from the nearest cable box, whether the resident becomes a subscriber or not. Any antennas or satellite dishes no longer in use must be removed within sixty (60) days from discontinued use.

Except for satellite dishes under forty inches (40) in diameter, no owner, resident, or lessee shall place or maintain any objects, such as masts, towers, poles, television, and radio antennas, on or about their property without prior written approval of the ECC.

No activity shall be conducted on any lot that causes an unreasonable electromagnetic interference with equipment such as, but not limited to, computers, telephones and television or radio reception, of any neighboring property.

The ECC may require the owner to paint, screen, or place antennas and satellite dishes, so that they do not create a visual nuisance to neighboring properties, if such requirements do not:

- (a) Unreasonably delay or prevent installation.
- (b) Unreasonably increase the cost of installation.
- (c) Preclude reception of an acceptable quality signal.

5.02 CULVERTS AND DRAINAGE (ARTICLE VI – SECTION 14) (ARTICLE VII – SECTION 5)

All plans for culverts and drainage must be submitted to the ECC for approval. No owner shall do any work, construct any improvement, place any landscaping, or suffer the existence of any condition whatsoever that shall alter or interfere with the drainage pattern established in connection with the approval of the final subdivision and parcel maps applicable to LOPA by Nevada County except to the extent that such alteration in drainage pattern is approved in writing by the ECC and County.

5.03 DRIVEWAYS

All lots are to have a paved driveway. All new, improved, or replacement driveways shall be a minimum of twelve (12) feet wide and shall extend from the edge of the street paving to the entrance of the garage. The edge of the driveway may be no closer than five (5) feet from the side property line. Driveways are to be completed and finished in a workmanlike manner acceptable to the ECC. When culverts are installed, concrete bulkheads will be required.

Driveways are approved for parking only within the homeowner's property lines not to encroach upon the LOPA property.

Secondary driveways must also conform to these driveway standards and prior ECC approval is required. Paving, however, is only required from the street pavement to the property line.

All owner modifications or improvements beyond the front property line and onto Association property require prior ECC approval as per Article VII, Section 1(b) of the LOPA CC&Rs. Improvements of any sort cannot encroach into the FUEL MODIFICATION AREA, a ten (10) foot strip of land abutting the roadway. (See EC standard 6.04.1 for details). Any such modifications or improvements are the lot owners' responsibility to maintain it in a neat and orderly fashion. NO excavation is allowed without prior ECC approval.

EXCEPTION TO THE ABOVE RULE: If a lot owner wishes to landscape into the FUEL MODIFICATION AREA further steps need to be taken. An application to the Environmental Control Committee is required. Proposed landscaping must conform to the strict provisions of Nevada County Ordinance. Said ordinance limits the type and size of allowable plants, the pattern of planting and requires ongoing maintenance plus irrigation. A review of EC Standards section 3.06 is therefore relevant. The Association will require the execution of a basic MEMORANDUM OF UNDERSTANDING AND MAINTENANCE AGREEMENT.

5.04 EXTERIOR LIGHTING (ARTICLE VI – SECTION 16)

All exterior lighting requires ECC approval. Lights such as fluorescent, mercury vapor, sodium or amber vapor and standard outdoor lights of the type used for security must be enclosed in a manner that directs the light in a specific area without causing a visual impairment to passing motorists or a nuisance to other residents. The issue of whether a nuisance exists shall be determined by, and at the sole discretion of, the ECC.

5.05 FENCING: DECORATIVE, INVISIBLE/PET, ELECTRICAL

(ARTICLE V – SECTION 1b) (ARTICLE VI – SECTION 20)

Article VI, Section 20 of the LOPA CC&Rs read, in part, that “In order to preserve the natural quality and aesthetic appearance of the existing geographic areas within Lake of the Pines, all property lines shall be kept free and open one to another.” Consequently, all fencing on individual residential lots must be submitted and approved by the ECC prior to installation. This includes vines, shrubs, and trees when they are placed close enough together that they form a visual barrier. When appropriate, natural vegetation is encouraged in place of other fencing materials. Vegetative fencing is encouraged on the residential side of the LOPA perimeter fence on Combie and Magnolia Roads.

Property line planting requires special attention to detail to meet the requirement of openness from one property to another. To avoid the possibility of future encroachment issues and/or the creation of a visual barrier in violation of the Governing Documents size at maturity must be considered. A five (5) foot open space between shrubs and tree canopies at maturity is required.

These fence standards apply to residential properties and do not apply to fences on common area, Association fences or perimeter fencing bordering the community.

- (a) Fence plans submitted to the ECC for approval must include a plot plan denoting the property dimensions, structures, and detailed dimensions of the area to be fenced. The plan must also show the type of fence materials, length, height, and color. All fencing must be constructed and maintained in a workmanlike manner.
- (b) Fences may not be installed within the following setbacks:
 - (1) Thirty (30) feet from the front property line.
 - (2) Five (5) feet from the side property line.
 - (3) Ten (10) feet from the rear property line
- (c) In no case should any fencing or combination of fencing enclose more than ten percent (10%) of the total lot area, as said lot area is shown on the recorded County map.
- (d) Fencing should not exceed six (6) feet in height unless County regulations specify a different height.
- (e) Fencing is to be constructed of an open design (not solid fencing) and is to be of a color and material that blends with the landscape. Fencing such as wrought iron, metal tubing, welded wire or vinyl lattice are examples of approved fencing materials. If wire and/or lattice is used, top, bottom and sides must be framed. Colors should be black, brown, dark green or the color of the house, as appropriate. Posts should be four inches by four inches (4”x4”) redwood or treated wood, or metal posts for metal tubing or wrought iron. “T” posts and chicken wire are not approved fencing materials. Please contact the LOPA EC office for examples of materials and designs if needed.
- (f) All fencing is considered temporary, and removal may be required at the owner’s expense upon change of use, sale of property, and deterioration of appearance. New owners must submit a new fencing application to the ECC for continued use of prior approved fencing.
- (g) Decorative fencing shall not exceed two (2) feet in height measured from the ground to the uppermost part of the top rail nor shall the supporting posts or pickets exceed thirty-six (36) inches in height.
- (h) Decorative and safety fencing may be allowed within setbacks with ECC approval and boundary line verification.
- (i) Temporary fencing is permitted in certain circumstances for up to two (2) years to protect young plants from deer foraging while the plant grows above the reach of the deer. Temporary plant protective fencing is not for plants with a mature height of less than six (6) feet and new plants should be purchased in an appropriate size to allow the branches to grow above the protective fence within two (2) years. Temporary fencing should surround individual plants, not groups of plants, with gaps between fencing at least equal in width to the adjacent temporary fence. Temporary plant fencing may be constructed out of wire fence, up to six feet (6) tall, supported by metal stakes located at the perimeter of the plant. Only black and dark green wire and posts are allowed.

(j) Invisible/Pet Fencing:

1. Invisible fencing includes any control system that is intended to restrain a pet or limit its ability to leave a specified area, such as an electrically triggered restraint and other means that are not normally visible to the average naked eye. Areas contained by invisible fencing may not include the front yard or areas that visitors would normally use to enter the property. Although in concept such systems seem highly desirable because of lack of visual obstruction, there are several other considerations.
 - a. Invisible fences do not exclude other animals or people from entering the confinement area.
 - b. Once a pet escapes the limited boundary of the invisible fence, the pet is free to roam at will and is without restraint, and in fact, the same restraint that was keeping him in, may now keep him out.
 - c. Since the restraint is (by definition), invisible, any passerby will be unaware the pet is restrained.
2. Invisible fence systems must meet the following criteria before they can be approved by the ECC.
 - a. Signage must be placed conspicuously at the property lines, with twenty (20) foot intervals between signs to alert passersby of a pet restrained by an invisible fence.
 - b. Neither the invisible fence nor the extreme limit of the pet's range may be closer than five (5) feet from the side property lines and fifteen (15) feet from the rear property lines.
 - c. As stated above, any pet that displays aggressive behavior, as determined by the Public Safety Department or ECC, will not be allowed to use an "invisible fence" system.
 - d. Any pet which escapes its "invisible fence" system will not be allowed to continue using it and must be physically restrained by other approved means.
 - e. Any electronic cable designed to be on, or under the ground, must be placed in a manner so that it does not pose a hazard to people walking over it.

For all fence proposals, the ECC shall consider the aesthetics of the proposed fencing and screening, along with the general policy of the CC&Rs to keep property lines open and to avoid possible adverse impacts resulting to neighboring lots.

5.05.1 SAFETY FENCING

Safety fencing that is intended to protect individuals from hazards, such as a swimming pool, pond, hole, trench, drop-off, or other hazard, must be designed in compliance with County Codes. Safety fencing could also be used to enclose an area for children to play. The recommended material is wrought iron. The material must be painted a color that blends in with the surroundings to reduce its visual impact. Suggested colors are brown, black, and dark green.

- (a) Pool fencing is normally required to have self-closing and self-latching gates, be six (6) feet in height, non-climbable and any openings must be small enough that they will not allow a four (4) inch diameter sphere to pass through. Pool fencing must also meet the requirements under the above Sections 5.05 and 5.05.1 but must also maintain a maximum distance of fifteen (15) feet from the water line of the pool.
- (b) A border fence defining a drop-off in a driving area or a barrier fence for personal protection, such as a guardrail, shall not exceed three (3) feet in height (or as required by code) and shall not extend further than needed for its purpose. Wood pole or split rail fencing can also be used in this situation.
- (c) Other safety fencing will be evaluated on a case-by-case basis by the ECC.
- (d) Safety fences that are needed for enclosures must be connected to the house. These areas should be limited to seven hundred fifty (750) square feet or fifteen (15) percent of the backyard area (whichever is more), three hundred (300) square feet or fifteen (15) percent of the front yard (whichever is more) and would typically not be allowed in side-yards for lots to remain open one to another.

5.05.2 PRIVACY FENCING

Privacy fencing can be short segments of plants, lattice, fencing or a combination of them. Short segments are considered eight (8) feet or less with at least two (2) feet between a panel or screen segments, and not exceed eight (8) feet in height. A maximum of five (5) eight-foot (8) feet panels will be permitted on any

property. A maximum length of twenty-four (24) feet of solid fencing may be permitted. Appropriate uses may be to limit the view from window-to-window on nearby homes, or to screen objectionable views of adjacent properties. If lattice is used as a privacy fence, it must be suitably framed on the top and bottom rails, using a minimum two inch by four-inch (2" X 4") framing material, and be constructed and maintained in a workmanlike manner. Privacy fencing should be painted to match the house or as approved by the ECC. Contact EC for more information. See also screening in section 5.05.3.

5.05.3 SCREENING

Screening is a term used for the concealment of any stored item, including but not limited to wood piles, trash containers, lawn and garden equipment and any other items that may be considered a visual nuisance. All screenings require ECC approval.

Previously approved screening that was installed in accordance with that approval and has been well maintained and currently presents a visually attractive appearance, will not be required to conform to these regulations. However, EC may require the owner to remove or modify such screening if it is no longer being used for the previously approved purpose.

Screening may be accomplished by a combination of materials, provided said screening is in keeping with the visual environment of the surrounding area as determined by the ECC. It is the goal of the ECC that screening itself is not to be unsightly or a visual nuisance. Natural screening with landscaping should always be the priority.

- (a) Tarps or covers are not considered approved screening materials but may be used in conjunction with other screening methods. Brightly colored tarps can themselves be a visual annoyance to your neighbors. The bright blue plastic tarps are not acceptable, although the same material in dark brown, dark green, or black, may be acceptable if they blend with the surroundings.
- (b) When lattice is used as screening, only the small "privacy lattice, with openings of two (2) inches or less will be accepted, it must be suitably framed with top and bottom rails, using a minimum two inch by four-inch (2" X 4") framing material or equivalent, and be constructed and maintained in a workmanlike manner.
- (c) Screening should meet privacy fencing in section 5.05.2 and specifically be no more than 5 total panels of 8' max in height and 8' maximum in length each. No more than 3 panels (8' each) or 24' total of continuous screen.
- (d) If the approved screening is not properly maintained, or fails to adequately screen the approved item, the item and screening must be removed or relocated.

5.05.4 STORAGE OF RV's, CAMPER SHELLS, BOATS, TRAILERS, ETC. (ARTICLE VIII – SECTION 17)

CC&R'S Article VIII, Section 17 states:

(d). In order to maintain a pleasant aesthetic appearance within Lake of the Pines, the storage of recreational vehicles on any Lot shall only be permitted if the vehicle can be parked and screened from view so as to avoid creating a visual nuisance. The Board of Directors may adopt criteria to determine what constitutes a visual nuisance:

...If such storage and screening cannot be achieved on a Lot, the recreational vehicle must be stored outside of Lake of the Pines. As used in this subparagraph (d) the term "recreational vehicle" means and includes any motor home, any truck with camper unit that is designed for human occupancy, and trailers, buses, boats, or trucks. It shall not be considered a violation of the preceding subparagraph to park a recreational vehicle on a LOT for periods up to 72 hours for purpose of loading and unloading, cleaning, or the housing of visiting guests. At the discretion of the Association's management, reasonable extensions of this 72-hour parking exception may be permitted.

- (a) All recreational vehicles, including but not limited to motor homes, trailers, boats, and camper shells must be stored at a location outside of the community unless otherwise-approved by ECC or LOPA. All boats, trailers and RV equipment must have current LOPA registration decals and/or applicable DMV decals affixed. LOPA will monitor this upon property inspections.
- (b) No lot owner or tenant shall have the inherent right to park or store any of these items on their property.
- (c) Storage/screening should only be given favorable consideration for approval when the plan includes either an existing barrier and/or vegetation in size and density to fully screen the subject item with

respect to any other lot or common area within LOPA. In these instances, the item being stored must basically be unnoticeable and blend with the surroundings.

- (d) ECC approval of storage and screening plans does not preclude future requirements for relocation or additional screening if more restrictive guidelines are adopted, neighbor complaints are received, or the screening does not adequately meet the objectives as described in the approved plans or these documents. Approved screening must be properly always maintained.
- (e) When screening is approved, it is for the item at time of approval only. You must resubmit when an item is changed, e.g., boat to pontoon boat, RV, etc.
- (f) It shall not be considered a violation of the preceding to park a recreational vehicle on a lot for periods up to seventy-two (72) hours within any seven-day period, for the purpose of loading or unloading, cleaning, maintenance, or the housing of visiting guests. Reasonable extensions of this seventy-two (72) hour parking privilege may be granted by ECC if applied for and approved in writing.
- (g) It is the intent of these regulations that no regular or consistent parking of recreational vehicles is allowed, whether for periods of less than seventy-two (72) hours or not.

5.06 FUEL TANKS (ARTICLE VI – SECTION 23)

All new enclosures must comply with the Uniform Fire Codes (UFC), as well as satisfy the LOPA rules for screening. Plan submittal to the ECC is required prior to placement or screening.

Fuel tanks (LPG = Liquefied Petroleum Gas) located above ground are to be screened and painted to blend with the environment.

In-ground tanks are now available from most LPG suppliers, and for obvious reasons, are the most preferred type of tank installation. Although the cost is higher than an above ground tank, some of that cost may be offset by the lack of required screening. They may also solve several landscaping problems and increase the value of your property. Check with your LPG supplier and/or EC for more information.

The items listed below have been summarized from the California Fire Codes and the Higgins Area Fire Protection District.

Current UFC Code applies to each item including the following: (Please see current UFC Code for specifics)

- (a) Container Location: There must be a minimum of ten (10) feet separation between containers and buildings (including eave lines), public ways and lines of adjoining property that can be built upon. Containers must also be located to mitigate any flooding or electrical hazards.
- (b) Clearance to Combustibles: Weeds, grass, brush, trash or any flammable or combustible material must be kept not less than ten (10) feet from any LPG container, piping, or regulators.
- (c) Safety Devices: Safety devices on LPG containers, equipment and systems shall not be tampered with or made ineffective in any way.
- (d) Protection of Containers: When, due to the proximity of alleys, driveways, public ways or parking areas, vehicular protection will be required when determined by the Higgins Fire District.
- (e) Installation: Shall be in accordance with all building, fire, and local ordinances.
- (f) Enclosures: Shall be in accordance with all codes including any enclosure must be constructed of non-flammable and/or non-combustible materials such as rock, brick, or concrete blocks.
- (g) Plans and Permits: Prior to any installation or relocation of tanks, contact the Nevada County Planning Department for plans and permits.

5.07 HEATING AND AIR CONDITIONING EQUIPMENT (ARTICLE VI – SECTION 23)

Exterior placement of heating and air conditioning units require ECC approval. The preferred location for placement is at the back of the home unless a more favorable location can be determined. Depending on location and visibility, ECC approved screening may also be required.

5.08 LANDSCAPING (ARTICLE V – SECTION 1 & 10) (ARTICLE VI – SECTION 22)

Landscaping is not necessarily required if the owner maintains the lot in a neat and attractive fashion and controls erosion. However, the ECC has the authority to require landscaping as a condition of approval for any plans submitted and for lots that are visually offensive and/or are subject to excessive erosion.

5.08.1 NEW OR CHANGED LANDSCAPING

LOPA goals are that landscaping designs blend with the surrounding natural terrain and environment. The use of native plants and materials is encouraged, and care must be taken to ensure that landscaping does not violate other sections of these Standards. The ECC is very concerned with the mature growth of any plantings, therefore all landscaping, whether structural or vegetation in nature, must receive ECC approval prior to building or planting. The only exception to this is the ground cover, flowers and shrubs that do not exceed three (3) feet in height at mature growth. Include full botanical name and size of plant at maturity.

All owner modifications or improvements beyond the front property line and onto Association property require prior ECC approval as per Article VII, Section 1(b) of the LOPA CC&Rs. Improvements of any sort cannot encroach into the FUEL MODIFICATION AREA, a ten (10) foot strip of land abutting the roadway. (See EC standard 6.04.1 for details). Any such modifications or improvements are the lot owners' responsibility to maintain it in a neat and orderly fashion. NO excavation is allowed without prior ECC approval.

EXCEPTION TO THE ABOVE RULE: If a lot owner wishes to landscape into the fuel modification area, further steps need to be taken. An application to the Environmental Control Committee is required. Proposed landscaping must conform to the strict provisions of Nevada County Ordinance. Said ordinance limits the type and size of allowable plants, the pattern of planting and requires ongoing maintenance plus irrigation. A review of EC Standards section 3.06 is therefore relevant. The Association will require the execution of a basic memorandum of understanding and maintenance agreement.

Plan very carefully when you submit landscaping plans for trees. What looks good today may be too tall and restrict views in the future, e.g., Redwoods and some species of pines can easily grow more than fifty (50) feet high with branches that can spread out twenty (20) feet to thirty (30) feet in diameter.

- (a) Deer resistant shrubbery is recommended, and a list of deer resistant plants may be obtained at the EC office and local nurseries.
- (b) Spraying for vegetation control of large areas must be approved by the ECC and Public Works, as it may cause erosion and lake pollution.
- (c) The outdoor cultivation of marijuana is not allowed within LOPA.

Examples of firewire landscaping can be found here: <https://www.nevadacounty.com/landscaping-with-firewise-plants-in-western-nevada-county/>

5.08.2 TREE REMOVAL (ARTICLE VI – SECTION 24)

No tree or trunk of a multiple trunk tree that is over three (3) inches in diameter at its narrowest point (as measured four (4) feet above the ground) may be removed from any lot without prior written approval of the ECC. The exception to this is a tree planted by the current or prior property owner and the planting of such tree(s) was not mandated by the ECC. It is also prohibited to bring harm to any such tree through excessive topping or trimming, spiking, or chemical use. ECC approval for the removal of dead, dying or dangerous trees will be based on an arborist report submitted to the ECC. No mitigation fee will be required for trees removed with ECC approval based on the arborist's report or based on Firewise recommendations.

For the sole benefit of the property owner of any LOT, if they would like to remove a tree for better use and/or enjoyment of their lot, the tree removal will be allowed as follows.

- (a) Submit a plan of your lot and identify all trees with trunks having a diameter of three (3) inches or greater (diameter measured four (4) feet above the ground), by type and location.
- (b) For lots with three (3) to twelve (12) trees, one (1) tree can be removed every ten (10) years. For lots with thirteen (13) to twenty-two (22) trees, two (2) trees can be removed every ten (10) years. For lots with twenty-three (23) to thirty-two (32) trees, three (3) trees can be removed every ten (10) years. For lots with over thirty-two (32) trees, up to ten (10) percent of the trees may be removed every ten (10) years. The ten (10) year period will begin with the removal of the first tree and reset every ten (10) years.
- (c) A tree mitigation fee will be paid to LOPA for each tree removed based on the size of the tree. The

tree size is the diameter of the tree measured four (4) feet above ground. For multi trunk trees, a measure of each trunk four (4) feet above the ground will be used for the total size but considered one (1) tree. For trees three (3) inches to fourteen (14) inches in diameter, the fee per tree is shown in the LOPA Fee Schedule (multi-trunked trees up to eighteen (18) inches of total trunk diameter). For trees between fourteen (14) inches and twenty-eight (28) inches, the fee per tree is shown in the LOPA Fee Schedule (multi-trunked trees between eighteen inches (18") and twenty-eight inches (28") of total trunk diameter). For trees over twenty-eight (28) inches, the fee per tree is shown in the LOPA Fee Schedule, these larger trees are evaluated by ECC differently due to their size and considered a "heritage" based on the size of the tree. These mitigation funds will be used by LOPA for landscaping in the parks and/or common areas not on the golf course.

Any unauthorized removal or harmful actions that cause removal will result in a fine. Additionally, the ECC may require the owner to plant new trees up to the total diameter of the tree(s) removed, with the location of such plantings also requiring ECC approval.

EC may require the removal of dead or otherwise hazardous trees according to the following procedures:

- (a) If deemed necessary, an inspection will be made by the Association's certified arborist who will document the hazardous, diseased, or insect infested condition of the tree(s).
- (b) A warning letter will be issued stating the basis for concern and requesting the owner to remove the hazardous tree(s) within thirty (30) days.
- (c) Should the subject tree(s) not be removed by the owner within thirty (30) days, the EC will issue a citation and notify the owner that they have an additional fifteen (15) days to remove the tree(s), or the Association will have the tree(s) removed and bill the owner.
- (d) Downed infected trees are not to be left at the site. The disposition of a downed infected tree is to be dealt with as directed by the Association's arborist.
- (e) Once approval has been obtained, trees shall be removed to ground level.

5.08.3 LAWN AND YARD ORNAMENTS

Any lawn or yard ornaments over three (3) feet in height or three (3) feet in width, must be approved by the ECC. Any lawn ornament that is considered a visual nuisance by the ECC will be subject to removal. All lawn ornaments and/or yard art should maintain a setback of at least five (5) feet from all property lines and/or street right of way lines. Additional setbacks may be required on a case-by-case basis or for sight lines along roadways or at intersections. Flagpole with height limit of twenty give (25) feet from the ground.

5.09 MAILBOXES (ARTICLE VI – SECTION 26)

The aesthetic appearance of mailboxes in the subdivision is of ECC concern, therefore the location, design and color require ECC approval. However, it is the owners' responsibility to meet any requirements of the U.S. Postal Service (USPS). The support structure must be adequate to maintain the mailbox in a secure and attractive fashion and must be maintained by the owner to continually meet these requirements.

The grouping of mailboxes is encouraged. Those that are still using an individual unit mailbox and want a cluster mailbox can get information from the USPS. Those who have cluster boxes cannot revert back to an individual mailbox unit.

5.10 NEWSPAPER RECEPTACLES

Newspaper receptacles are often ill placed and inadequately maintained, which makes them unattractive and a visual nuisance to our community. Whenever possible, newspaper receptacles should be securely attached to the mailbox support structure or grouped together near cluster mailboxes in a neat and orderly fashion. Do not just allow your newspaper carrier to place them indiscriminately. Be considerate of the visual aspect to the community in their placement.

If the EC finds a newspaper receptacle ill placed or inadequately maintained, the procedures as described under "6.00 Property Maintenance" will be followed, requesting the owner to take corrective action.

5.11 PATIOS, WALKWAYS, GOLF CART PATHS. (ARTICLE VI – SECTION 17)

Due to possible drainage problems to neighboring yards, property line proximities, easement issues, etc., all

patios, walkways and golf cart paths must be approved by the ECC.

5.12 SOLAR PANELS (ARTICLE VI – SECTION 10)

Solar panels, whether being used on existing or new structures, must be approved by the ECC. Plan submittal must include the location of the panels and a manufacturer's brochure giving the description of the panels, including colors and surface finishes. Panels must be as unobtrusive as possible with minimum impact upon the visual environment. All connecting plumbing must also blend with the existing background. Bright or reflective materials are not acceptable. Plans should show location for fixtures and routing of all conduits. Conduit and all exposed mounting hardware should be painted to blend with the adjacent surface.

5.13 SWIMMING POOLS (ARTICLE VI – SECTION 18)

All swimming pools must comply with the county ordinances relative to the construction and location of swimming pools. A permanent fence is required around the pool area, the design of which must be submitted to EC for approval. Permanent fencing within five (5) feet of any property line or within any easement is prohibited. Additionally, swimming pool fencing must be a maximum of fifteen (15) feet from the pool's waterline. For further details see Sections 5.05 and 5.05.1.

5.14 YARD AND PLAY EQUIPMENT (ARTICLE VIII – SECTION 16)

The goal of these Standards is to allow the use of recreational equipment without diminishing the esthetics of our natural wooded environment or causing visual intrusion or excessive noise.

5.14.1 TEMPORARY USE YARD AND PLAY EQUIPMENT

For use in these standards, "Temporary Use" yard and play equipment include, but is not limited to trampolines (black, brown, or dark green) wading pools, portable basketball hoops, small children's toys, lawn games, etc., or any other outdoor equipment that is normally stored until used and put away when not in use.

It is not the intent of these standards to disallow the use of these "Temporary Use" items and therefore they do not require ECC approval. However, it is the intent of these standards to prevent the accumulation and visual nuisance of such items.

Temporary use items must be stored out of sight when not in use and must not be allowed to accumulate, be stored, or left scattered on a property in view of others.

5.14.2 SEASONAL AND PERMANENT USE YARD AND PLAY EQUIPMENT

For use in these standards, "Seasonal and Permanent Use" yard and play equipment includes but is not limited to swing/slide/gym sets, playhouses, trampolines, above ground pools, basketball hoops, lake equipment and toys, etc., or any item that is not designed or is impractical to store when not in use. ECC approval is required prior to the placement of these seasonal and permanent use items. Seasonal items may be in place from Memorial Day through Labor Day.

- (a) Location approval for any such item will be dependent on the visual impact of the item, its proximity to neighbors, potential noise, and safety. The rear yard placement of all such equipment on golf course lots requires a fifteen (15) foot set-back from the rear property line. Placements immediately adjacent to streets or common areas also require a fifteen (15) foot setback.
- (b) The height and size of any such item should not be intrusive or encroach on the normal viewing area of neighboring homes.
- (c) Bright colors or reflective surfaces will not be allowed without approved screening. The color(s) of such items should be neutral, black, brown, or dark green.
- (d) Screening may be required to reduce the visual impact on neighbors and must be submitted to the ECC for approval.
- (e) All yard and play equipment must be maintained in a clean, neat, and safe manner.
- (f) Any yard and play equipment that is no longer being used, or falls into disrepair, or becomes unsightly, or when the tenant vacates the property, or upon sale of the property, must be removed, unless the new tenant / owner re-submits and receives approval from the ECC. Any screening that was installed must also be removed unless it is specifically resubmitted to and approved by the ECC.

6.00 PROPERTY MAINTENANCE (ARTICLE VII – SECTION 2) (ARTICLE IV – SECTION 4a, III)

Proper property maintenance is an important part of meeting the LOPA community goals. The goals of maintenance are to prevent and minimize the spread of fire, provide an attractive natural forested surrounding for our homes, maintain all structures in an unobtrusive manner to blend with the natural surroundings and to provide as little visual impact on our neighbors as possible.

Each owner shall be responsible for the maintenance and repair of his or her residence and lot. All lots, whether occupied or unoccupied, and any improvements placed thereon, shall always be maintained in such a manner as to prevent them from becoming unsightly or hazardous, by reason of substandard exterior painting or maintenance of structures, failure to trim or otherwise maintain landscaping, or by permitting the accumulation of weeds, rubbish, or debris on the lot. Both developed and undeveloped lots must always be maintained so that weeds and grasses do not exceed four (4) inches in height.

If an owner fails to perform maintenance or repair functions, the Association may give written notice to the offending owner with a request that they correct the failure within fifteen (15) days. If the owner fails to perform any necessary repair or maintenance, the Association may exercise its rights under the CC&R's Article III, Section 3(b), to enter the owner's lot and perform the necessary repair or maintenance at the owner's expense, so long as the owner has first been given notice and the opportunity to either initiate voluntary compliance or has requested a hearing in accordance with CC&R's Article XIII, Section 6.

6.01 BUILDINGS AND STRUCTURES

For the purposes of this section "buildings and structures" include all man-made things placed upon a lot. They include, but are not limited to, homes, garages, outbuildings, sheds, decks, shade screens, gazebos, cabanas, boat lifts and their covers, fences, pools and play structures.

- (a) All buildings or structures must be approved by the ECC and shall be maintained in a neat and workmanlike manner. That maintenance is to include the structural integrity, approved colors, stains, and esthetic appearance, like what was originally approved. EC may require a property owner to repair or remove a structure if it is not properly maintained.
- (b) Replacement, repair, or maintenance of any structure within LOPA must meet the requirements of the Nevada County Building Codes. Additional requirements may be imposed by the ECC as stated elsewhere in this document.

6.02 STORAGE OF PERSONAL PROPERTY (ARTICLE VIII – SECTION 16)

No owner or occupant shall place, store, or collect any item on his or her premises that would cause a visual nuisance, fire, or safety hazard. Refusal to remove or properly store objectionable and offensive objects will result in appropriate action by the Association. The definition of what is considered objectionable, and offensive is at the sole discretion of ECC.

- (a) Unsightly cars, parts thereof, trailers, boxes, packing crates, cartons, bottles, cans, discarded furniture, toys, lumber, or any other objects that fall into this category must be removed or properly stored.
- (b) When not in use, small seasonal items such as lawn & garden equipment, seasonal play equipment, etc., must be stored in approved sheds or covered and screened by ECC approved methods.
- (c) Trash containers must be screened from view. See Section 5.05.4
- (d) Tarps or covers are not considered approved screening materials but may be used in conjunction with other screening methods.

6.02.1 STORAGE OF FIREWOOD

The storing of firewood must combine proven fire safety precautions and consider the visual aspects of a woodpile. A review of available resources including Nevada County, CAL FIRE, LOPA Firewise Committee, and the National Fire Prevention Agency combined with Environmental Control standards establishes the following rules to help keep the Immediate Fire Zone around homes safe.

Three (3) cords of firewood is the maximum that can be stored on any single lot. Setbacks of five (5) feet for side yards and fifteen (15) feet for rear yards apply. Firewood is to be neatly stacked with ten (10) foot

clearance around and above. The minimum distance from houses, garages and decks shall be thirty (30) feet. During inclement weather months of December 1 through May 1, temporary limited storage of firewood will be allowed on a porch, deck, or covered area adjacent to a home.

DISTANCE EXCEPTION: The thirty (30) foot distance requirement can be reduced to ten (10) feet if and only if the woodpile is fully covered with an approved flame-retardant tarp. The tarp is to be CPAI-84-7 or NFPA 701 certified and must be securely fastened and maintained in good condition. The clearance requirement of ten (10) feet around and above applies. Acceptable tarp colors are black, brown, and gray.

6.03 DRAINAGE STRUCTURES, DITCHES AND SWALES (ARTICLE VII – SECTION 5)

Owners must keep drainage courses, ditches, and swales on their lot free and clear of all obstructions, and shall, in cooperation with contiguous property owners, maintain all such drainage ditches, swales and culverts common to their lots in good order.

No owner or residence shall alter or obstruct a drainage course, or materially add to the natural water volume of the drainage course, without making adequate provisions with respect to neighboring lots and common areas. Any alterations, obstructions, or additions to drainage structures or water volume shall be considered a work of improvement and is subject to ECC approval.

6.04 FIREWISE

LOPA is a Firewise Community. Decisions made by the ECC for new projects such as building plans and landscaping will consider the principles of Firewise to prevent the creation or spreading of fire within LOPA. Member requests for the modification or removal of structures, or roadside vegetation as recommended by Firewise, will also consider Firewise principles. Additional information regarding LOPA Firewise can be obtained via the LOPA website or the LOPA Firewise Committee.

6.04.1 ROADSIDE FIRE SAFETY

NEVADA COUNTY ORDINANCE mandates certain actions and conditions involving roadside **FIRE SAFETY** affecting all properties in the county. THE LAKE OF THE PINES ASSOCIATION owns a strip of land sixty (60) feet in width meandering throughout the community which is dedicated exclusively to roads. All roads are classified as private roads and not county roads. Therefore, the Association has a duty to comply with, implement, maintain, and enforce all elements of said ordinance. The objective is to reduce the risk of roadside vegetation contributing to the spread of fire and improve the flow of vehicle traffic in the event of evacuation.

Many roads within the community have various markings such as center lines, driving lane markings, outer edge of roadway markings (aka the fog line) and walking path markings. The area designed for vehicle travel is known as the roadway. Any area beyond **the roadway** is commonly referred to as “the shoulder” which may be partially paved. At some point beyond the shoulder the front property line of adjoining parcels will be reached.

A designated strip of land abutting the roadway is labeled **THE FUEL MODIFICATION AREA (FMA)**. Said **FMA** is a strip of land ten (10) feet in width starting at the outer edge of the roadway marked by the fog line. Most often the majority if not all this strip of land will be Association owned. There may however be instances where the **FMA** encroaches onto private property.

The **FMA** between the edge of the fog line and the private property line (Association owned land) is to be free of all plants and trees. CC&Rs Article VII Section 1a) references this matter. However, certain plantings are available and are discussed below. At the discretion of The Association, trees not identified as “Hazardous Vegetation” may remain within the FMA provided they are limbed up to and limbs maintained at a height above at least fifteen (15) feet.

FMA LANDSCAPING OPTIONS FOR LOT OWNERS: The ordinance allows restrictive planting to occur within the FMA. If a lot owner wishes to landscape into the FMA certain steps need to be taken. An application to the Environmental Control Committee is required. Proposed landscaping must conform to the strict provisions of Nevada County Ordinance. Said ordinance limits the type and size of allowable plants, the pattern of planting and requires ongoing maintenance plus irrigation. A review of EC Standards section

3.06 is therefore relevant.

Plant selection is critical and controlled by the restrictions contained within the ordinance. Vegetation that is combustible in its natural state that will readily ignite, burn, and transmit fire is considered "**HAZARDOUS VEGETATION**". This type of vegetation **therefore cannot be in the FMA**. Examples include junipers, eucalyptus, bamboo, and oleanders. Allowable plants include those with a high moisture content that grow close to the ground and have a low sap and resin content.

Fire resistant plants within the **FMA** are to be maintained with four (4) feet of open space between plants at maturity and to a height of not to exceed two (2) feet. The planting pattern must be in a mosaic pattern (a coherent pattern—see example below).

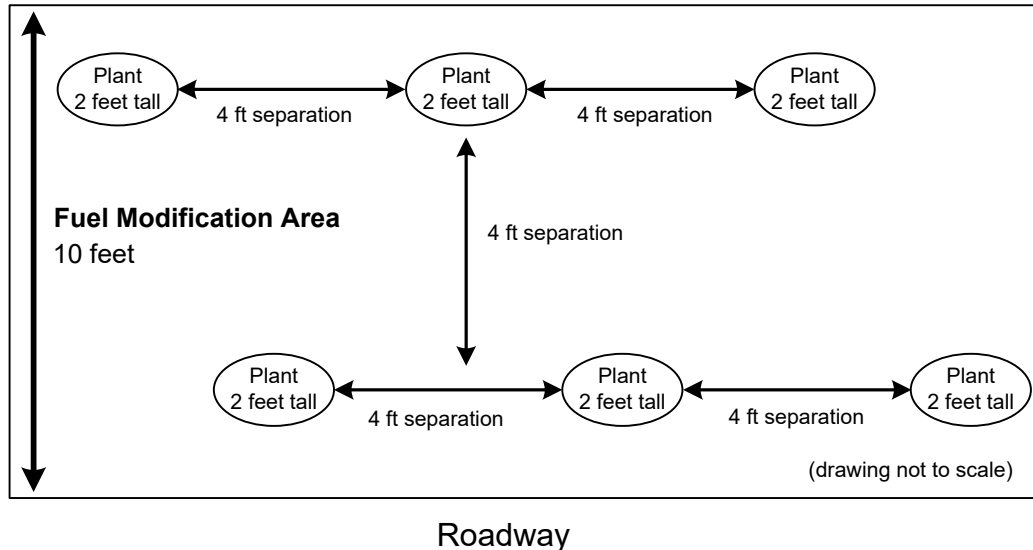

A partial list of acceptable plants based on Fire Safe Council training material, Western Nevada County Gardening Guide and University of California Extension Nevada County Master Gardeners is provided below:

Partial List of Allowed Fire-Resistant Plants

- Heuchera spp - Coral Bells
- Achillea spp - Yarrow
- Aquilegia spp - Western Columbine
- Dicentra spp - Western Bleeding Heart
- Fragaria spp - Strawberry
- Iris spp - Douglas Iris
- Penstemon spp - Beard Tongue
- Sisyrinchium Bellum spp - Blue Eyed Grass
- Sedum spp – Stone Crop
- Dudley and Echeveria spp – Live Forever

Selecting plants, other than those listed above, that meet the FMA fire-resistant planting criteria requires some investigation. Several websites offer helpful information on selecting acceptable plants. One such list, from a Bay Area community, is provided in Attachment 1.

Master Gardener assistance is also available at most local nurseries.

Evidence as to plant eligibility will be required as part of the ECC application for authorization to plant within the **FMA**.

Grass areas in the **FMA** must always be maintained down to four (4) inches or less. Trees in or overhanging said area must be limbed up and maintained to a height of fifteen (15) feet.

BEYOND FRONT LOT LINE LANDSCAPING OPTION: The CC&Rs and EC Standards address lot owner planting between the front lot line and the beginning of the **FMA**. See sections 2.05, 5.03 or 5.08.1 of the

EC Standards.

FMA ENCROACHMENTS ONTO PRIVATE PROPERTY: While highly unlikely, that portion, if any, of the ten (10) foot strips of land (FMA) that lies within private property must be landscaped and maintained in accordance with the same provisions listed above for landscaping within the **FMA**.

Many roads within the community have no centerline or fog line markings. Therefore, individual measurements need to be taken to identify what would otherwise be classified as the roadway and what would be identified as the FMA. This can be accomplished by locating the physical center between both outer edges of pavement and proceeding a combined total twenty (20) feet toward individual properties. The first ten (10) feet on each side of the center line is to be classified as roadway with the next ten (10) feet strip of land classified as the FMA. The vegetation rules and planting options listed above also apply to all Association owned property within the FMA identified by this method.

Private properties within the cul-de-sac portion of the streets cannot be measured in the same manner as properties along a straight section of pavement. Therefore, all that is required is that no vegetation encroaches onto the area beyond the front property line. Any tree limbs overhanging the property line must be trimmed up and maintained to a height of fifteen (15) feet.

These standards apply to each, and every property located within Lake of The Pines.

7.00 MISCELLANEOUS ITEMS

7.01 BURNING (ARTICLE VIII – SECTION 9)

No outside burning of trash, garbage, building, or landscaping material is allowed. The Association shall provide a site for the disposal of tree and plant materials in an appropriate location with access to such location at least twice a year (Parcel E).

7.01.1 FIRE PITS

- (a) Burning of wood, presto-logs, or any other combustible material (Class-A fuels) in portable or stationary fire pits will only be allowed with an approved functioning protective ember screen in place and must be installed according to manufacturers' guidelines.
- (b) Burning of Class-A fuels in portable or stationary fire pits must be located a minimum of ten (10) feet from any structures and any overhanging or nearby vegetation.
- (c) Open Air Fires (bon-fires) on personal property and/or on any LOPA Association Property are prohibited. Violations will result minimally in a noxious activity citation.
- (d) Unsafe and reckless use of wood burning fire pits will result in a noxious activity citation.
- (e) Fire Pits should be closely monitored at all times.
- (f) NO Fire Pits burning of Class A fuels shall be allowed when LOPA Public Safety posts an "Extreme Fire Day" or Red Flag Warning "Extreme" fire danger level days as determined by the National Fire Danger Rating System.
- (g) Use of Liquid Propane Gas (LPG) Fire Pits, which do not cause embers, may be used all year round.
- (h) Fire Pits shall comply with all Local, County, State & Federal regulations.
- (i) All Manufactured Fire Pits using LPG must have CSA and UL Certification and be installed according to manufacturers' instructions.
- (j) Permanent Fire Pits require ECC approval before installation.

7.02 DISPOSAL OF REFUSE (ARTICLE VIII – SECTION 8)

Trash, ashes, garbage, or other refuse shall not be dumped or stored on any lot, nor be thrown into or left on the shoreline of any lake. Any trash that is accumulated by an owner outside the interior walls of a residence shall be stored entirely within appropriate covered disposal containers that are screened from view from any street, neighboring lot, lake, golf course, or other common area. Any extraordinary accumulation of rubbish, trash, garbage, or debris shall be removed promptly to a public dump or trash collection area by the owner or tenant at his or her expense.

7.03 HOME BUSINESS AND COMMERCIAL ACTIVITIES

(ARTICLE VIII – SECTIONS 4, 7, 12) (P&P HOME BUSINESS OR OCCUPATION)

7.03.1 GENERAL STATEMENT

As stated in both the CC&R's and the Policies and Procedures, all properties other than those belonging to the Association are for single family, residential use only. However, the ECC may grant a variance in the form of a permit for the operation of a business from a residence. Any such permit shall be considered a conditional, revocable privilege, and the operation of that business must consistently meet both the spirit of the Association's Governing Documents and any other requirements of the CC&R's, LOPA Policies and Environmental Standards.

7.03.2 DEFINITION

For the purposes of this section, a home business is defined as any commercial activity that is performed from the home or property and is clearly incidental and subordinate to the properties use for residential purposes. CA Health and Safety Code, Section 1597.45(b), and Section 1597.40 (c), precludes small home daycare centers for children from being considered a "home business", however such home daycare centers must still abide by all other Association guidelines on noise, parking, visual nuisance, etc. The following is a list of the specific articles and sections that pertain to the operation of a Home Business within LOPA. You should study these before planning to operate a business from your home.

- (a) CC&R's Article VIII, Section 4 (Exclusive Residential Use & Improvements of Lots).
- (b) CC&R's Article VIII, Section 7 (Prohibition of Noxious Activities)
- (c) CC&R's Article VIII, Section 12 (Business Activities)
- (d) Environmental Standards, Section 7.05 (Nuisance or Hazards)
- (e) Environmental Standards, Section 7.09 (Signs)
- (f) Policies & Procedures, "Home Business or Occupation"
- (g) Rules & Regulations, "Hours of Construction"
- (h) Rules & Regulations, "Contractors / Workers"
- (i) Rules & Regulations, "Parking"

7.03.3 PERMIT APPLICATION & FEES

The "Home Business Application" is available at the EC office and must be completed in its entirety, signed by applicant and property owner and submitted with the Home Business Application Fee. Once approved, the permit is valid for a period of twelve (12) months from the date of approval and must be renewed annually. The ECC may solicit comments from neighbors within a reasonable distance before considering whether or not to grant a home business permit.

The submission of a Home Business Application expressly authorizes members of the ECC to occasionally visit the outside of that property for the purpose of confirming that the conditions of the permit are being consistently maintained.

7.03.4 RESTRICTIONS (POLICIES & PROCEDURES – HOME BUSINESS OR OCCUPATION – PAGE 9d).

- (a) No person other than a resident of the property shall be engaged in any home business conducted thereon.
- (b) The use of the property for any home occupation shall be clearly incidental and subordinate to its use for residential purposes and shall be contained entirely within any one building located on the property; and further provided that not more than twenty-five percent (25%) of the floor area of the dwelling unit or not more than four hundred (400) square feet of the floor area, whichever is greater shall be used in conducting any such home occupation, nor shall any home occupation be conducted in more than one accessory building, the use thereof which shall not exceed one thousand (1,000) square feet.
- (c) There shall be no change in the outside appearance of the building or premises, or any other visible evidence of the conduct of any such home business, including, but not limited to, the storage of material and/or equipment outside of any building. The parking of a "commercial vehicle" around the home is also prohibited unless specifically approved by the ECC.
- (d) No noticeable business activity conducted Monday through Saturday shall begin prior to 7:00 am and will cease by 7:00 pm or one hour before dusk, whichever is earlier. No noticeable business activity

will be allowed at any time on Sundays or the following holidays: New Year's Day, Memorial Day, Independence Day, Labor Day, Thanksgiving Day, and Christmas Day.

- (e) No "Home Business" shall depend on customer traffic and cannot generate more than six (6) business related visits in any single day.
- (f) Any "Home Business" or "Home Occupation" shall be limited to a maximum of five (5) hours during any normal working day.
- (g) No business activity is allowed that interferes with the normal residential atmosphere of the properties, or causes an excessive increase of noise, odor, visual nuisance, storage, traffic, or parking, around any home.
- (h) No equipment or process shall be used which creates vibration, glare, fumes, odors, or electrical interference, and no equipment or process shall create any off premises visual or audible interference in any radio or television receivers or fluctuations in line wire voltage.
- (i) No equipment or process shall create noise more than fifty-five (55) decibels as measured at any property line. (Noise level measurement made pursuant to this section shall be measured with a sound level meter using the A-weighted scale, and the "slow" response, pursuant to the manufacturer's instructions).

7.03.5 ENFORCEMENT

- (a) Failure to maintain the conditions stated above, or listed in the application, or in the letter of approval, or failure to submit an application and receive approval for a home business when the conditions in Section 7.03.3 of this document exist, may subject the tenant and/or property owner to fines.
- (b) Complaints will be investigated by EC, and if a violation is found, a written directive will be issued to the person(s) responsible for the home business or occupation and the property owner, advising that corrective measures must be undertaken within the specified period. The directive will also include a warning of possible fines and/or loss of the "Home Business Permit" if any future violations are found.

7.04 HOUSEHOLD PETS (ARTICLE VIII – SECTION 10)

The right of residents to have pets shall be subject to the following restrictions.

- (a) A reasonable number of common household pets may be kept on each lot so long as they are not kept or bred for commercial purposes. No other animals, livestock, or poultry of any kind shall be kept, bred, or raised on any lot or in any residence.
- (b) Permitted household pets shall only be allowed in the common areas of LOPA when they are leashed and under the supervision and control of their owners.
- (c) Pet owners shall be responsible for the prompt removal and disposal of all pet waste.
- (d) Pet owners shall be solely responsible for the conduct of their pets. The Association, its Board, Officers, Employees and Agents shall have no liability for any damage or injury to persons or property caused by any pet.
- (e) The Board of Directors shall have the right to establish and enforce additional rules and regulations, defining in a uniform and nondiscriminatory manner, what constitutes a "reasonable number" of pets, depending on their size, disposition and/or maintenance requirements.

7.05 NUISANCE OR HAZARDS (ARTICLE VIII – SECTION 7 & 13) (ARTICLE XIV – SECTION 3)

No noxious, offensive, or hazardous activity shall be carried out on any lot, nor shall anything be done on any Lot that shall be, or become, an unreasonable annoyance or nuisance to the neighborhood. For the purposes of this policy the word "nuisance" shall be defined as the omission or commission of any act that is, or that results in an outcome that is, offensive to owners or occupants of any dwelling unit within a reasonable distance from where the alleged nuisance emanates.

No resident shall permit any condition to exist upon his or her lot which shall induce, breed, or harbor infectious plant diseases, rodents, or noxious insects. The existence of a nuisance or hazard shall be deemed to exist when EC signs a notice addressed and delivered to the owner or occupant of any lot on which a nuisance or hazard is created. Such notice may be delivered by hand or by mail.

Delivery of such notice to the U.S. Postal Service and addressed to the last known address of the occupant or owner, shall be considered the same as delivery to the owner or occupant. All notices and demands required by this Declaration which are served by mail shall be by first-class or certified mail, with postage prepaid, and shall be deemed delivered four days after deposit in the United States mail in the County.

Said nuisance or hazard must be abated within the specified time after delivery of such notice. The Association may, by appropriate proceedings, institute action to enforce abatement.

7.06 PARKING (ARTICLE VIII – SECTION 17)

- (a) Vehicles shall not be parked on a regular or consistent basis on any association street or common area and in no event shall a vehicle be parked along a street in a manner which encroaches upon the paved surface of the roadway or creates a risk or hazard.
- (b) No vehicle may be parked in any area of a lot other than an ECC approved parking area, such as a driveway or ECC approved parking pad.
- (c) Commercial vehicles, other than pickups with a standard bed, or family style vans, are prohibited from overnight parking on any street or lot unless they receive prior written approval from the ECC.
- (d) Any EC approved parking area or pad, with direct access from LOPA streets, easements, or Common Area shall be paved.
- (e) Parking in an approved improvement area must comply with all parking rules and regulations in accordance with LOPA CC&Rs and Governing Documents.

7.08 SALE OF RESIDENTIAL PROPERTY (VIOLATION CORRECTIONS OF PRIVATE PROPERTY FOR SALE)

All residential property shall be inspected by the E.C. Manager for violations of the Association's Governing Documents and EC Standards prior to its sale. Members are encouraged to request pre-sale inspections to speed up the process and avoid delays.

The E.C. Manager shall notify the administration of any noted violations. The administration shall advise the title company and seller in writing of any noted violations. California State Law (Civil Code 1102) requires the seller to disclose all such violations to the prospective buyer. Should the violations not be corrected prior to the final date of property transfer, the LOPA Association shall hold the buyer fully responsible for correcting the violations, at the buyer's expense, and within the time period stipulated by EC. In addition, "Member in Good Standing" status will be withheld until the violations are corrected.

7.09 SIGNS (ARTICLE VIII – SECTION 11)

In respect of the goal to maintain a natural setting within LOPA, the display of signs, posters, banners, or any brightly colored or visually intrusive object is strongly discouraged.

7.09.1 HOUSE AND LOT NUMBER SIGNS

- (a) House number signs are required on all developed lots and must be placed at the side of the driveway most centered to the lot. These signs are to be of a uniform size, color, and material, as approved by EC. Signs are brown with white reflective numbers and can be ordered from Higgins Fire District.
- (b) During construction of a new home, either a lot number sign or a house number sign must be visible from the street. The sign must be neat and of a non-intrusive color and design and fixed to a freestanding stake. The sign must be in place prior to plan approval and remain in place during the entire construction period. Attachment of signs to trees is not permitted.

7.09.2 COMMERCIAL SIGNS

No commercial signs of any type may be posted, placed, erected, or stored in view of any property within LOPA except as expressly listed within these governing documents.

7.09.3 REAL ESTATE SIGNS

For the purpose of this section, "Real Estate Signs" include any "For Sale", "For Rent", "For Lease", "Open House", or other signs relating to similar property transactions.

- (a) Real estate signs must be mounted on a single freestanding stake or post painted the ECC approved brown color. The post can be no more than four (4) feet in height and must not be placed on any Association Easement or Common Property. Signs adjacent to or facing the lake or golf course are

strictly prohibited.

- (b) All real estate signs, including attachments, must be brown with white lettering and are limited to an eighteen inch by twenty-four-inch (18" x 24") area. One clear plastic brochure box of a size adequate to hold a single facing of an eight and one half by eleven-inch (8.5" by 11") brochure is allowed if attached to the same post, and below, the real estate sign.
- (c) All real estate signs must be maintained in a neat, professional, and orderly manner.
- (d) All real estate signs must be removed at the close of escrow or immediately upon execution of lease/rental agreement.
- (e) Open house signs are allowed on the day of the open house only and must be removed that day.

7.09.4 NON-COMMERCIAL SIGNS

Although the posting of signs, posters, or banners is strongly discouraged, the homeowner has the right to post such items if they meet the following criteria.

- (a) Non-commercial signs must be placed totally within the property owner's boundaries and cannot be placed within any easement area. Placement of signs may not interfere with safety or access, nor infringe upon the view from neighboring or common areas. No signs may be posted on Association property or common areas without prior written approval from the ECC.
- (b) No sign or banner of any type may be attached to any tree, pole, fence, mailbox, vehicle, or anything other than their own support, unless directly attached to the home or other permanent structure. The only exception to this is a small "For Sale" sign temporarily placed on a vehicle or boat.
- (c) No sign can be made up of lights, reflective materials, roofing, siding, paving materials, flora, balloons, or any other similar building, landscaping or decorative component, and no sign may be painted directly upon any structure.
- (d) No sign may exceed nine (9) square feet in size.
- (e) No flag or banner may exceed fifteen (15) square feet in size.
- (f) All signs must comply with local, state, and federal laws.
- (g) One (1) double sided Yard or Garage sale sign will be allowed under the following conditions:
 - (1) It must meet the maximum nine (9) square foot size limitation.
 - (2) It must not be posted earlier than seventy-two (72) hours prior to the start of the event.
 - (3) It must be removed within twenty-four (24) hours of its placement or upon completion of the event, whichever occurs first.
 - (4) It must meet all other pertinent criteria within this document.
- (h) Posting political signs will be limited to forty-five (45) days prior to an election, and removal of political signs must be accomplished within five (5) days after each election. Placement must only be on private property with the owner's permission.

7.10 VIEW OBSTRUCTIONS (P&P – VIEWS & SOLAR ACCESS)

Some of the most appealing aspects of LOPA are its magnificent views and natural forested setting. However, as vegetation increases in size, it invariably restricts views. This is inescapable and could only be mitigated by the continuous pruning, topping and/or removal of mature trees or shrubs, which may not only have a negative impact on their health, but also affect the overall appearance of the community.

Since there are so many variables involved, it is not realistic or practical to set finite rules regarding view issues, therefore any action on requests submitted to the ECC for the removal or trimming of trees or shrubs, whether on the requesting party's property or a neighboring property, will be at the sole discretion of the ECC. The ECC may or may not require the appropriate property owner to prune or remove the tree(s) or shrub(s) in question. The ECC shall consider the species and maturity of the tree(s) or shrub(s), the impact that they have on the view in question, and whether their removal is consistent with the LOPA natural forested setting.

Property owners are encouraged to plan very carefully when they submit landscaping plans for trees or shrubs. What looks good today may be too tall and restrict views in the future. e.g., Redwoods and some species of Pines can easily grow in excess of fifty (50) feet high with branches that can spread out twenty (20) feet to thirty (30) feet. ECC approval to plant trees or shrubs does not preclude them from any future requirements to prune or remove them.

In accordance with the CC&R's Article VII, Section 2 and page 43 of the Policies and Procedures, Views

and Solar Access, owners are responsible for the maintenance of the trees and shrubs on their property.

- (a) Views, as defined in this policy, shall be construed as seen from the primary location of a residence as determined by the ECC after discussion with the view seeker. From that primary view location, a member may request up to a forty-five (45) degree angle line of sight with its center perpendicular to the residence structure.
- (b) Members are not entitled to an unobstructed view corridor. For use in determining the view corridor, the term "picture window view" will be considered. That is, the view may be filtered by the presence of trees and branches, trees and approved structures.
- (c) Property owners cannot expect to retrieve a view that is better than what was present when they purchased the property, or what may be diminished by the natural growth of approved vegetation.
- (d) Should members feel that their view is unreasonably restricted, they must file a written appeal to the ECC for subsequent review and determination of action. The ECC shall conduct inspections of properties as they deem necessary to determine validity of the appeal.
- (e) Should the ECC feel that any appeal regarding views or solar access is valid, equitable solutions should be sought that not only protects the complainant but also protects property values of tree owners, including shade provided by the trees and the like. However, trees and other vegetation must be maintained in a manner that respects the views and solar access of neighboring owners.
- (f) While every attempt will be made to only require the trimming of selective branches on offending trees, it may be necessary to remove a tree, and that determination will be at the sole discretion of the ECC. This would be particularly applicable where groupings of trees are present, and the removal of a tree would not impact the aesthetic character of the property. In the case where a member has severely trimmed or topped a native species resulting in abnormal growth, there may be occasion for the ECC to require additional maintenance or removal of the tree in question. If the ECC feels that the expertise of a certified arborist is needed, one may be contacted.
- (g) Should any decision by the ECC not be acceptable to either party, further appeals may be forwarded to the Board of Directors for review. Failure by the tree owner to comply with any decisions requiring tree maintenance may result in monetary penalties as stipulated by the Board of Directors.

8.00 COMMUNITY INSPECTIONS FOR NONCONFORMING USE & COMPLIANCE VIOLATIONS

(ARTICLE V – SECTION 11,13) (ARTICLE VIII – SECTION 12)

It is the intent of the CC&Rs to ensure a pleasant environment for all members of the LOPA community. To aid in ensuring the ongoing maintenance of the standards outlined in the CC&R's, and further detailed in these Environmental Standards, periodic inspections will be conducted throughout the community. These inspections are to include the private properties of all members as well as the properties of the Association. The locations from which these inspections are made, and the procedures for noted violations, are addressed in the following Sections 8.01 & 8.02.

If a violation is reported or discovered, the matter will be investigated by EC and a determination shall be made regarding the violation.

8.01 LOCATION OF INSPECTIONS

Routine inspections of all properties governed by these Standards may be conducted from the following locations:

- (a) From all common roadways throughout LOPA.
- (b) From all areas of the golf course.
- (c) From all navigable areas of the lake.
- (d) From the parts of Combie Road that offer a view into LOPA properties.
- (e) From the parts of Magnolia Road that offer a view into LOPA properties.
- (f) From any other area in or around LOPA that is accessible without trespassing on private property.
- (g) From neighboring properties if permission to pass is provided by the owner(s)/occupants of those properties.

8.02 VIOLATION PROCEDURES

8.02.1 FIRST VIOLATION (ARTICLE IV – SECTION 4b) (ARTICLE V – SECTION 11b)

If a violation is noted, both the owner and tenant (if applicable) shall be notified in writing. All such letters shall meet the requirements stated in “notices”, Article XIV, Sections 1, 2 and 3. The letter of notification will include the general nature of the violation, the reference of the violation, the date the violation was noted, a statement of the recommended methods to correct the violation, and a statement of how much time will be allowed to correct the violation. The letter will also state the approximate interval until a re-inspection will occur to confirm that the violation has been corrected.

A copy of the letter(s) will be retained and stored by lot number in a file for that lot and will be held for a period of no less than twenty-four (24) months from the date of the first letter. A re-inspection will be conducted after the time stated in the first letter. If the violation has been corrected by that time, no further action will be taken.

8.02.2 CONTINUING VIOLATIONS

If re-inspection finds that the violation remains, a “Notice of Fine” letter will be sent to both the owner and occupants. This letter will remind them of the first letter, the nature of the violation and the fact that the violation has not been corrected. This “Notice of Fine” letter will also notify the owner/tenant that fines will begin on the mailing date of the letter and additional fines may increase per EC Standard 8.02.3 below. It will also advise the owner/tenant that they have the right to appeal, advise them how much time they must make that appeal, and provide instructions on how to perform the appeal. A copy of this letter will be retained in the lot’s file for a period of not less than twenty-four (24) months.

8.02.3 REPEATED VIOLATIONS

It is reasonable to assume that once a member is cited for and corrects a violation, they should clearly understand both the letter and the intent of the regulation(s) for which they were cited. As a result, the following provisions are further provided.

- (a) If a member is cited for the same or similar violation twice or more in any twenty-four (24) month period, at the second (2nd) and any subsequent notice of that violation, the “Notice of Violation” shall automatically become a “Notice of Fine”, as stated in Section 8.02.2 above, and the fines will begin on the mailing date of this notice.
- (b) Nothing in the above should be construed in a way that would suggest that a member, once cited and fined for the violation of one regulation, might automatically be fined for their first violation of a different regulation.

8.02.4 APPEAL PROCESS

Processes for appeal shall be maintained to ensure due process and fairness in the application of charges as set forth in this policy. It is intended that any member who has been issued a violation may appeal said violation to the Covenants Committee and finally to the Board of Directors. A request for an appeal to the Covenants Committee shall be filed in writing by the alleged violator within thirty (30) days of the postmark of the notice of fine(s) or the date of personal delivery. A request for an appeal to the Board of Directors shall be filed in writing by the alleged violator within ten (10) days of the postmark of the Covenants Committee decision notice. Appeals related to ECC project decisions shall go directly to the Board.

9.00 ECC REVIEW OF ASSOCIATION PROPERTY

Recognizing that the ECC is charged with the responsibility of supervising the orderly development of the community and has a unique awareness and perspective on the visual desires of the community, the Association Management and Board of Directors are encouraged to request the review and input of the ECC on any Association or Common Property project that may impact the visual and aesthetic issues of the community.

Such issues may include the planting or removal of trees, placement, painting, and selection of colors for buildings or other structures on common grounds, maintenance of buildings, structures and lands belonging to the Association, and any other items that may have high visibility to our community.

10.00 REVISIONS

These Environmental Standards must be reviewed, and if needed, updated by the ECC in their entirety no

less that once a year to ensure they remain current. Rule change procedures must conform to California Civil Code's Section 4340 – 4370.

The latest revision of these Standards cancels and supersedes any previous Standards. These Standards may be amended or revised only by (a) a majority vote of the ECC, and (b) the approval of the Board of Directors. The revision date must be shown on the cover sheet of this document.

Minor corrections or changes that do not affect policy or procedure will not be considered a "revision", unless deemed by the ECC to be of significant difference to make the previous issue obsolete. These corrections or changes will be documented in memorandum to the Administrative Office file so as to be included in the first subsequent update.

11.00 DEFINITIONS OF TERMS WITHIN THIS DOCUMENT

By-Laws – The official LOPA Governing Document entitled "Restated By-Laws".

CC & R's – The official LOPA Governing Document entitled "Restated Declaration of Covenants, Conditions and Restrictions".

Common Area – All real property owned by the Association for the common use and enjoyment of the Owners (streets, lakes, parks, golf course, tennis courts, etc.).

Drip Lines – The outer extremities of roofs, eaves, decks, steps, enclosed patios, etc. and are used in determining setbacks.

Dwellings – Any Dwelling or addition to any dwelling on any lot shall be constructed by the method commonly known as "stick building" or other ECC approved methods predominantly used in the prevailing home building industry on an on-site constructed foundation, sub floor or slab. The dwelling or addition shall be constructed in accordance with the Uniform Building Code as required by Nevada County Building Department.

Easement – An interest in land owned by another that entitles its holder to a specific limited use or enjoyment. Refer to the CC&R's Article IX for the definition of certain easements within LOPA.

EC – The LOPA "Environmental Control Department".

ECC – The LOPA "Environmental Control Committee". The ECC is appointed by the Board of Directors and is responsible to the Board for monitoring environmental conditions within the boundaries of LOPA, including development and maintenance of architectural standards. The ECC is charged with the responsibility for orderly development of the community, protection of property values and the rights of all lot owners. The ECC is appointed, structured, and operated under the directions of the Restated Bylaws, Article IX, Section 1.

Utility Encroachment Fee – A fee paid to the Association to cover the administrative costs associated with field inspections, posting and maintenance records.

Environmental Standards – "Standards" – The LOPA "Environmental Standards and Requirements for Architectural Review".

Family Members – A husband, wife and their children, blood relatives, or others sharing common ancestry, or maintaining a common household.

Fence – A visible or tangible obstruction which may be a hedge, wall, trestle, frame of wood, wire, or any line of obstacles interposed between two portions of land so as to partition off one from the other.

Foundation Line – A line contiguous with the outer extremities of the foundation under the main structure, garage, decks, steps, or enclosed patios.

Kitchen – A room or area intended or designed to be used, or which is used, for the preparation or cooking of food. The definition of a Kitchen does not include wet bars, home office coffee making areas, or other areas that are incidental to a kitchen and not intended for the use of cooking or preparation of meals.

Landscaping – Is any activity that adorns, improves, or artistically arranges any LOT. For the purpose of these Standards, landscaping is also defined as any vegetation, structure, or ornament that exceeds three (3) feet in

height or will exceed three (3) feet in height at mature growth.

LOPA – “Lake of the Pines”.

LOT – Any parcel of real property designated by a number on any Subdivision Map for LOPA, excluding the Common Areas. When appropriate within the context of this Declaration, the term “LOT” shall also include the Residence and other Improvements constructed or to be constructed on a LOT. Any reference herein to a “neighboring LOT” shall mean and refer to any LOT that has a portion of which is within a three hundred (300) foot radius of the LOT in question.

LSE – Lake Spillway Elevation is one thousand five hundred seven (1507.0) feet above sea level,

Maximum Grade – The highest point of elevation on a LOT within five (5) feet of the foundation line.

Owner – A person or persons who appear as the owners of a fee simple interest in a LOT, as disclosed in the Official Records of the Office of the Nevada County Recorder.

Performance Deposit – A deposit paid to the Association prior to any construction of a Living Area, Garage, Addition, or any Alterations thereof, to assure that all construction is in accordance with the approved plans and conforms with the LOPA Governing Documents. This includes the removal of exterior debris and the cleanup of all Association road and drainage easements. Deposits may be refunded in part or whole, depending on compliance with the Environmental Standards and satisfactory sign-off of the ECC final inspection.

Plan Check Fee – A fee paid to the Association upon submittal of plans to EC, to cover administrative costs for reviewing plans to assure that they comply with LOPA Association governing documents. Fees are normally non-refundable, however, if construction is canceled within one (1) year, all but the actual costs incurred by the Association will be refunded.

P&P (Policies and Procedures) – The official LOPA Governing Document entitled “Policies and Procedures”.

Riprap – A loose assemblage of stones at the water’s edge to prevent wave rebound and/or erosion.

R&R (Rules and Regulations) – The official LOPA Governing Document entitled “Rules and Regulations”.

Screening – A term used for the concealment of any item.

Seawall – A protective structure of stone, concrete, bricks, or wood that creates an embankment to prevent erosion of a shoreline.

Setback – A setback is the minimum distance from a lot’s property line to the drip line or outer limits of any structure, including but limited to a house, garage, shed, gazebo, pool, hot tub, deck, dock, fence, etc.

Sewer Permit Fee – A fee paid to the Association to cover administrative costs associated with field inspections of sewer projects and providing information to the Contractor.

Single Family Dwelling – A structure containing not more than one kitchen and is designed or used for the occupancy of one (1) family.

Single Story Dwelling – A single story dwelling is defined as having all living space on one level. If the finished floor level is directly above a garage (or other under floor space at the same level) for more than fifty percent (50%) of its total area, then such garage and under floor space shall be considered a story.

Split-Level Dwelling – A split-level dwelling is defined as living space on multiple levels with the top-level conforming to the profile of a single-story structure from maximum grade.

Story – That portion of a building included between the upper surface of any floor and the upper surface of the floor next above, except that the top-most story shall be that portion of a building included between the upper surface of the top-most floor and the ceiling or roof above. The minimum height above the surface of the floor and the ceiling or roof above shall conform to the Uniform Building Code.

Ridge Pole – A pole erected on the building site indicating the height of the peak or ridge as measured from the

maximum grade. The ECC, at its discretion, may pick another more permanent point of reference to determine the maximum height of a structure.

Story Pole – A pole erected on the building site with short cross bars indicating height of each floor level and the height of peak or ridge as measured from maximum grade.

Tenant – Any person who is occupying a Residence and is not an Owner, or a member of the Owner's family, or a servant or care provider for a resident Owner.

Variance – An approval to conduct an activity, or to place, plant, or construct in a manner that is contrary to the LOPA Governing Documents.

ENVIRONMENTAL STANDARDS & REQUIREMENTS FOR ARCHITECTURAL REVIEW**INDEX**

SECTION	PAGE	SUBJECT
2.03	6	ADDITION PLAN SUBMITTALS
5.07	23	AIR CONDITIONING EQUIPMENT
5.01	18	ANTENNAS
1.08	3	APPEALS – ECC DECISIONS
8.02.4	36	APPEALS – VIOLATIONS AND FINES
1.04	2	APPROVAL – BASIC PROCESS
1.06	2	APPROVAL – TIME REQUIRED FOR EC APPROVAL
1.07	2	APPROVAL / DENIAL PROCESS
2.10	8	APPROVED PLAN MODIFICATION
9.00	36	ASSOCIATION PROPERTY – REVIEW BY THE ECC
4.07	16	BEACHES & SHORELINE PREPARATION
2.04	6	BOAT DOCK & LIFT PLAN SUBMITTALS
4.01	14	BOAT LIFTS AND COVERS
5.05.4	21	BOAT STORAGE
4.04	16	BOATS – DOCKING AND STORAGE
3.00	8	BUILDINGS AND STRUCTURAL PROJECTS
7.01	29	BURNING
4.02	14	CABANAS, LAKESIDE SHELTERS, GAZEBOS
5.01	18	CABLE TV
5.05.4	21	CAMPER SHELL STORAGE
5.14.2	24	CHILDREN'S PLAY EQUIPMENT
3.08	11	CHIMNEY & VENT PIPES
3.10	11	COLORS & EXTERIOR FINISHES
7.09.2	33	COMMERCIAL SIGNS
9.00	36	COMMON PROPERTY – REVIEW BY THE ECC
8.01	35	COMMUNITY INSPECTIONS – LOCATION OF INSPECTIONS
8.00	35	COMMUNITY INSPECTIONS – NONCONFORMING USE
8.02	35	COMMUNITY INSPECTIONS – VIOLATION PROCEDURES
3.16	13	COMPLIANCE CERTIFICATE
3.15	12	CONSTRUCTION INSPECTIONS
1.10.3	4	CONTRACTORS RESPONSIBILITY
2.08	7	COUNTY APPROVALS
5.02	18	CULVERTS
2.04	6	DECK PLAN SUBMITTALS
11.00	36	DEFINITIONS FOR ENVIRONMENTAL STANDARD
2.09	8	DEPOSITS AND FEES
3.02	8	DESIGN RESTRICTIONS
4.04	16	DOCKING AND STORAGE OF BOATS AND OTHER LAKE EQUIPMENT
4.03	15	DOCKS
4.03.1	15	DOCKS – DESIGN AND PLACEMENT
4.03.2	15	DOCKS – SIZE RESTRICTIONS
3.03	9	DRAINAGE
5.02	18	DRAINAGE
6.03	27	DRAINAGE DITCH MAINTENANCE
3.04	9	DRIP LINES
3.15.2	13	DRIVEWAY INSPECTIONS
5.03	18	DRIVEWAYS
4.08	16	EARTHEN SHORELINES
3.05	10	EASEMENTS
4.12	17	EASEMENTS – LAKESHORE
3.08	11	EAVES
1.02	2	ECC – WHO WE ARE, WHAT WE DO
3.06	10	ENCROACHMENTS

ENVIRONMENTAL STANDARDS & REQUIREMENTS FOR ARCHITECTURAL REVIEW**INDEX**

SECTION	PAGE	SUBJECT
1.09	3	ENFORCEMENT OF ENVIRONMENTAL COMPLIANCE MATTERS
11.00	36	ENVIRONMENTAL STANDARD DEFINITIONS
10.00	36	ENVIRONMENTAL STANDARD REVISIONS
1.03	2	ENVIRONMENTAL STANDARDS
3.07	11	EXCAVATION
3.10	11	EXTERIOR FINISHES
2.09	8	FEES AND DEPOSITS
5.05	19	FENCING – DECORATIVE
5.05	19	FENCING – ELECTRIC
5.05	19	FENCING – GARDEN
5.05	19	FENCING – GENERAL RESTRICTIONS
5.05	19	FENCING – PET
5.05.2	21	FENCING – PRIVACY
5.05.1	20	FENCING – SAFETY
3.15.3	13	FINAL INSPECTION OF NEW HOMES
7.01.1	29	FIRE PITS
6.04	27	FIREWISE
6.02.1	27	FIREWOOD - STORAGE
3.15.1	12	FOUNDATION INSPECTIONS
5.06	22	FUEL TANKS
2.03	6	GARAGE PLAN SUBMITTALS
2.04	6	GAZEBO PLAN SUBMITTALS
4.02	14	GAZEBOS, CABANAS, LAKESIDE SHELTERS
1.01	1	GENERAL INFORMATION
5.11	25	GOLF CAR PATHS
1.11.1	4	GRANDFATHERING – OVERVIEW
1.11.2	4	GRANDFATHERING – TIME TO CORRECT
1.11.3	5	GRANDFATHERING OF NON-APPROVED, NONCONFORMING USE
3.08	11	GUTTERS
7.05	32	HAZARDS
4.06	16	HAZEL LAKE
5.07	23	HEATING EQUIPMENT
3.01	8	HOME ADDITION GENERAL REQUIREMENTS
7.03.2	30	HOME BUSINESS – DEFINITION
7.03.5	31	HOME BUSINESS – ENFORCEMENT
7.03.1	29	HOME BUSINESS – GENERAL
7.03.3	30	HOME BUSINESS – PERMIT APPLICATION & FEES
7.03.4	31	HOME BUSINESS – RESTRICTIONS
7.03	30	HOME BUSINESS & COMMERCIAL ACTIVITIES
7.09.1	33	HOUSE & LOT NUMBER SIGNS
4.05	16	HUCK FINN POND
5.00	18	IMPROVEMENTS – NON-STRUCTURAL
3.15.2	13	INSPECTION – DRIVEWAYS
3.15.3	13	INSPECTION – FINAL (PRIOR TO OCCUPANCY)
3.15.1	12	INSPECTION – FOUNDATIONS
3.14	12	INSPECTION – ON-SITE PRIOR TO PLAN APPROVAL
3.15	12	INSPECTIONS – CONSTRUCTION
1.00	1	INTRODUCTION
1.09.1	3	INVESTIGATION OF APPARENT VIOLATIONS
4.09	17	LAKE ACCESS
4.00	13	LAKE FRONT IMPROVEMENTS
4.11	17	LAKEFRONT RETAINING WALLS
4.12	17	LAKESHORE – EASEMENT RESTRICTIONS

ENVIRONMENTAL STANDARDS & REQUIREMENTS FOR ARCHITECTURAL REVIEW**INDEX**

SECTION	PAGE	SUBJECT
4.10	17	LAKESHORE – RECLAMATION OF ERODED PROPERTY
4.02	14	LAKESIDE SHELTERS, CABANAS, GAZEBOS
5.08	23	LANDSCAPING
5.08.3	24	LANDSCAPING – LAWN & YARD ORNAMENTS
5.08.1	23	LANDSCAPING – NEW OR CHANGED
5.08.2	23	LANDSCAPING – TREE REMOVAL
2.05	7	LANDSCAPING PLAN SUBMITTALS
5.08.3	24	LAWN & YARD ORNAMENTS
1.13	5	LIABILITY – LIMITATION ON LIABILITY
5.04	21	LIGHTING – EXTERIOR
2.03	6	LIVING AREA PLAN SUBMITTALS
5.06	22	LPG TANKS
5.09	24	MAILBOXES
6.01	26	MAINTENANCE – BUILDINGS AND STRUCTURES
6.03	27	MAINTENANCE – DRAINAGE STRUCTURES, DITCHES, SWALES
6.00	26	MAINTENANCE – GENERAL
7.00	29	MISCELLANEOUS ITEMS
2.10	8	MODIFICATIONS TO APPROVED PLANS
2.02	6	NEW CONSTRUCTION PLAN SUBMITTAL
5.10	25	NEWSPAPER RECEPTACLES
5.00	18	NON-STRUCTURAL IMPROVEMENTS
7.05	32	NUISANCES'
1.10.1	3	OWNERS RESPONSIBILITY
7.06	32	PARKING
2.04	6	PATIO PLAN SUBMITTALS
5.11	25	PATIOS
5.05	19	PET FENCING
7.04	31	PETS
2.04	6	PLAN SUBMITTAL – DECKS, PATIO'S, POOLS, BOAT DOCKS, GAZEBOS, ETC.
2.03	6	PLAN SUBMITTAL – LIVING AREA AND GARAGE ADDITIONS
2.02	6	PLAN SUBMITTAL – NEW CONSTRUCTION
2.01	6	PLAN SUBMITTAL – OVERVIEW
2.00	6	PLAN SUBMITTAL – REQUIREMENTS AND FEES
2.05	7	PLAN SUBMITTALS – LANDSCAPING
2.07	7	PLOT PLANS
2.04	6	POOL PLAN SUBMITTAL
1.05	2	PROJECTS – TIME TO COMPLETE APPROVED PROJECTS
2.06	7	PROPERTY LINES
7.09.3	33	REAL ESTATE SIGNS
4.10	17	RECLAMATION OF ERODED LAKESHORE PROPERTY
7.02	30	REFUGE
3.01	8	REQUIREMENTS FOR STRUCTURAL PROJECTS
1.10	3	RESPONSIBILITY: OWNERS, TENANTS, & CONTRACTORS
3.02	8	RESTRICTION OF DESIGNS
10.00	36	REVISIONS OF THE ENVIRONMENTAL STANDARDS
6.04.1	27	ROADSIDE FIRE SAFETY
3.08	11	ROOF OVERHANGS
3.08	11	ROOF PITCH
3.08	11	ROOFING MATERIALS
5.05.4	21	RV STORAGE
7.08	32	SALE OF RESIDENTIAL PROPERTY
5.01	18	SATELLITE DISHES
5.05.4	21	SCREENING

ENVIRONMENTAL STANDARDS & REQUIREMENTS FOR ARCHITECTURAL REVIEW

INDEX

SECTION PAGE SUBJECT

SECTION	PAGE	SUBJECT
4.11	17	SEAWALLS AND RETAINING WALLS
3.04	9	SETBACKS
3.11	12	SEWER HOOK-UP
4.07	16	SHORELINE PREPARATION FOR BEACHES & LAKE ACCESS
4.08	17	SHORELINES – EARTHEN
7.09.2	33	SIGNS – COMMERCIAL
7.09	32	SIGNS – GENERAL
7.09.1	33	SIGNS – HOUSE AND LOT NUMBER
7.09.4	33	SIGNS – NON-COMMERCIAL
7.09.3	33	SIGNS – REAL ESTATE
5.12	25	SOLAR PANELS
1.09.2	3	STOP WORK ORDER
6.02	26	STORAGE – PERSONAL PROPERTY
5.05.4	21	STORAGE OF RV's, CAMPER SHELLS, BOATS, TRAILERS, ETC
3.09	11	STORAGE SHEDS
3.01	8	STRUCTURAL PROJECTS GENERAL REQUIREMENTS
5.13	25	SWIMMING POOLS
1.10.2	3	TENANTS RESPONSIBILITY
1.06	2	TIME REQUIRED FOR ECC APPROVAL
1.05	2	TIME TO COMPLETE APPROVED PROJECTS
5.05.4	21	TRAILER STORAGE
5.08.2	23	TREE REMOVAL
3.12	12	UNDERPINNINGS
3.13	12	UTILITY LINES
1.12	5	VARIANCES
3.08	11	VENT PIPES AND CHIMNEYS
7.10	34	VIEW OBSTRUCTIONS
1.09.1	3	VIOLATION INVESTIGATION
8.02	35	VIOLATION PROCEDURES
8.02.4	36	VIOLATIONS – APPEAL PROCESS
8.02.2	35	VIOLATIONS – CONTINUING
8.02.1	35	VIOLATIONS – FIRST
8.02.3	35	VIOLATIONS – REPEATED
5.11	25	WALKWAYS
5.08.4	24	WATERSHED LANDSCAPE MAINTENANCE
5.14	25	YARD AND PLAY EQUIPMENT
5.14.1	25	YARD AND PLAY EQUIPMENT – TEMPORARY USE
5.15.2	25	YARD AND PLAY EQUIPMENT – SEASONAL AND PERMANENT USE